

TT
185
G7



Class TT185

Book .C7



SH

600

BENCH WORK IN WOOD:

A COURSE OF

STUDY AND PRACTICE

DESIGNED

FOR THE USE OF SCHOOLS AND COLLEGES

BY

W. F. M. GOSS,

PROFESSOR OF PRACTICAL MECHANICS, PURDUE UNIVERSITY,
LAFAYETTE, INDIANA.



BOSTON, U.S.A.:

PUBLISHED BY GINN & COMPANY.

1902

TT185
.G7

Entered according to Act of Congress, in the year 1887, by
W. F. M. GOSS,
in the Office of the Librarian of Congress, at Washington.

51251
704

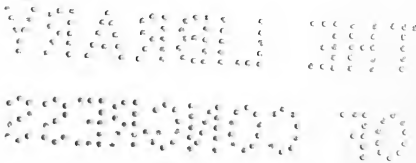

TYPOGRAPHY BY J. S. CUSHING & Co., BOSTON.

PRESSWORK BY GINN & Co., BOSTON.

4-10701/3

PREFACE.

TO avoid confusion, the subject herein treated is considered in three divisions. Part I. contains the essential facts concerning common bench tools for wood; it describes their action, explains their adjustments, and shows how they may be kept in order. Part II. presents a course of practice by which ability to use the tools may be acquired; and Part III. discusses such forms and adaptations of joints as will meet the requirements of ordinary construction. It is not expected that the student will complete Part I. before entering upon Part II., or that he will finish Part II. before commencing Part III. He will find greater profit in using them together. For example, a shop exercise involving the chisel (Part II.) should be accompanied or preceded by a study of the chisel (Part I.); again, the various forms of mortise and tenon joints (Part III.) will be better understood and more easily remembered, if considered during the time when types of such joints are under construction in the shops (Part II.). In the writer's experience with classes of students, one hour has been given to class-room work for every five hours given to shop work. By this apportionment, Parts I. and III. can be mastered in the class-room while Part II. is in progress in the shops.

The equipment necessary for carrying out the course of

practice given in Part II. is much less expensive than may at first appear. Besides a bench, a pair of trestles, and a bench-hook, the following-named tools are needed:—

1 2-ft. Rule.	1 24-inch Ripping-Saw, 6 teeth.
1 Framing-Square.	1 10-inch Back-Saw.
1 7-inch Try-Square.	1 8-inch Drawing-Knife.
1 8-inch Bevel.	1 Fore-Plane.
2 8-inch Marking-Gauges.	1 Jack-Plane.
1 Chalk-Line, with Chalk.	1 Smooth-Plane.
1 Lead-Pencil.	1 Set Auger-Bits, $\frac{1}{4}$ " to 1" by 16ths.
1 Scribe.	1 Bit-Brace.
Firmer-Chisels, 1 each, $\frac{1}{8}$ ", $\frac{1}{4}$ ", $\frac{3}{8}$ ", $\frac{1}{2}$ ", $\frac{5}{8}$ ", $\frac{3}{4}$ ", 1", and $1\frac{1}{2}$ ".	1 Brad-Awl.
Gouges, 1 each, $\frac{3}{8}$ ", $\frac{1}{2}$ ", $\frac{3}{4}$ ", and 1".	1 Carpenter's Hammer.
1 22-inch Cross-cutting-Saw, 8 teeth.	1 Mallet.
	1 Nail-Set.
	1 Oilstone.
1 pair 8-inch Dividers.	1 Hand-Scraper.
1 pair $\frac{3}{8}$ -inch Matching-Planes.	$\frac{1}{2}$ doz. Quill Bits, assorted from $\frac{1}{4}$ " down.
1 $\frac{3}{16}$ -inch Beading-Plane.	1 Miter-Box.
1 $\frac{1}{4}$ -inch Beading-Plane.	1 Grindstone.
1 Plow.	

If provision is to be made for more than one student, the items printed in small type need not be duplicated. One set of these will suffice for any number less than thirty.

The writer is indebted to Mr. M. Golden, of the School of Mechanics and Engineering, Purdue University, for the execution of many of the drawings and for valuable suggestions.

W. F. M. G.

PURDUE UNIVERSITY,
Lafayette, Ind.

CONTENTS.



INTRODUCTION. — INTERPRETATION OF MECHANICAL DRAWINGS.

	PAGES
1. Mechanical Drawings Defined. — 2. Plans. — 3. Elevations. — 4. Method of showing Parts Obscured from Sight. — 5. Sections. Section Lines. Cross-hatching. Incomplete Sections. — 6. Broken Drawings. — 7. Scale. — 8. Dimensions. Dimension Lines,	1-6

PART I. — BENCH TOOLS.

9. Bench. — 10. Bench-Stop. — 11. Vise. — 12. Bench-Hook. — 13. Trestles	7-9
--	-----

MEASURING AND LINING APPLIANCES.

14. Early Standards of Length. — 15. English Standard Yard. — 16. United States Standard of Length. — 17. The Troughton Scale. — 18. Rules. — 19. Framing-Square. — 20. Board-measure Table. — 21. Brace-measure Table. — 22. Try-Square. — 23. Bevel. — 24. "Miter-Square." — 25. Try-and-"Miter" Square. — 26. Dividers. — 27. Scribing with Dividers. — 28. Combining Square and Rule. — 29. Combining Square and Bevel. — 30. Setting the Bevel at an Angle of 60 Degrees. — 31. Setting the Bevel at any Given Angle. — 32. Marking-Gauge. — 33. Mortise-Gauge. — 34. Panel-Gauge. — 35. Cutting-Gauge. — 36. Chalk-Line. — 37. Scriber. — 38. Pencil	9-20
--	------

CHISELS AND CHISEL-LIKE TOOLS.

39. Firmer-Chisels. — 40. Framing-Chisels. — 41. Corner-Chisels. — 42. Gouges. — 43. Chisel Handles. — 44. Drawing-Knife. — 45. Action of Cutting Wedges. — 46. Angle of Cutting Wedge in Chisel and Gouge. — 47. Grinding. — 48. Whetting . . . 20-26

SAWS.

49. Efficiency. — 50. Form. — 51. Set. — 52. Size of Teeth. — 53. Ripping-Saw and Cross-Cutting-Saw Defined. — 54. Teeth of Ripping-Saws. — 55. Teeth of Cross-Cutting-Saws. — 56. Back-Saw. — 57. Compass-Saw 26-36

APPLIANCES FOR FILING AND SETTING SAWS.

58. Files. — 59. Sets for Bending the Tooth. — 60. Sets for Swedging the Tooth. — 61. Clamps 36-38

SAW FILING AND SETTING.

- 62 Top-Jointing. — 63. Setting. — 64. Filing. — 65. Side-Jointing, 39-41

PLANES AND PLANE-LIKE TOOLS.

66. Description of Planes. — 67. Length of Stock. — 68. Plane-Iron. Angle of Cutting Wedge. — 69. Outline of Cutting Edge. — 70. Use of Different Bench Planes. — 71. Action of Smooth-Plane and Fore-Plane Compared. — 72. The Cap. — 73. Narrowness of Mouth. — 74. Adjusting the Iron. — 75. Jointing a Plane. — 76. Iron Planes. — 77. Planes of Wood and Iron Combined. — 78. Circular-Planes. — 79. Block-Planes. — 80. Spokeshaves. — 81. Rabbeting-Planes. — 82. Matching-Planes. — 83. Hollows and Rounds. — 84. Beading-Planes. — 85. Plows. — 86. Combination Planes. — 87. Scrapers 41-52

BORING TOOLS.

88. Augers. — 89. Auger-Bits. — 90. Sharpening Augers and Auger-Bits. — 91. Center-Bits. — 92. Expansive Bits. — 93. Small Bits. — 94. Bit-Braces. — 95. Angular Bit-Stock. — 96. Automatic Boring Tool 53-59

MISCELLANEOUS TOOLS.

97. Winding-Sticks. — 98. Hand Screw-Driver. — 99. Brace Screw-Driver. — 100. Hammer. — 101. Hatchet. — 102. Mallet. — 103. Sand-Paper. — 104. Wooden Miter-Box. — 105. Iron Miter-Box. — 106. Clamps. — 107. Grindstone. — 108. Use of Water on a Grindstone. — 109. Truing a Grindstone. — 110. Truing Devices for Grindstones. — 111. Oilstones. — 112. Oil for Oilstones. — 113. Form of Oilstones. — 114. Oilstone Slips. — 115. Truing an Oilstone 59-69

PART II. — BENCH WORK.

116. Good Lines a Necessity. — 117. Location of Points. — 118. Jointed Face. — 119. Working-Face. 71-73

EXERCISE NO. 1. — MEASURING AND LINING.

120. Material. — 121. Spacing: Pencil and Rule. — 122. Lining: Pencil, and Framing-Square. — 123. Chalk-Lining. — 124. Lining: Pencil, and Try-Square. — 125. Lining: Pencil and Bevel. — 126. "Gauging" Lines: Pencil and Rule. — 127. Spacing: Scriber and Rule. — 128. Lining: Scriber, and Try-Square. 129. Lining: Scriber and Bevel. — 130. Gauge-Lining. — 131. Lining for Exercise No. 3 73-79

EXERCISE NO. 2. — CHISELING AND GOUGING.

132. Chiseling by Hand. — 133. Chiseling by Use of Mallet. — 134. Gouging 80-83

EXERCISE NO. 3. — SAWING.

135. Handling the Saw. — 136. Guiding the Saw. — 137. Correcting the Angle of the Cut. — 138. Rip-Sawing. — 139. Cross-cutting 83-86

EXERCISE NO. 4. — PLANING.

140. Handling the Plane. — 141. Why a Plane Clogs. — 142. Jointing. — 143. Planing to a Square. — 144. Method of Performing

	PAGES
Similar Operations. — 145. Smooth Surfaces. — 146. Sand-Papering	86-91
EXERCISE No. 5. — Box.	
147. Jointing to Width. — 148. Sawing to Length. — 149. Nailing. — 150. Hammer Marks. — 151. Setting Nails. — 152. Withdrawing Nails. — 153. Fastening the Box Bottom. Finishing the Box. — 154. Planing End Grain	91-96
EXERCISE No. 6. — BENCH-HOOK.	
155. Lining and Sawing. — 156. Using the Auger-Bit	96-98
EXERCISE No. 7. — HALVED SPLICE.	
157. Lining. — 158. Value of Working-Face Illustrated. — 159. Cutting the Joint. — 160. Sawing a Fit. — 161. Toeing Nails	99-102
EXERCISE No. 8. — SPLAYED SPLICE.	
162. Lining. — 163. Cutting and Finishing the Joint	103, 104
EXERCISE No. 9 — SIMPLE MORTISE-AND-TENON JOINT.	
164. Lining. — 165. Cutting the Mortise. — 166. Cutting the Tenon. 167. Making a Pin. — 168. Drawboring.	104-110
EXERCISE No. 10. — KEYED MORTISE-AND-TENON JOINT.	
169. Lining and Cutting. — 170. Key	110, 111
EXERCISE No. 11. — PLAIN DOVETAIL.	
171. Lining and Cutting. — 172. Gluing. — 173. Short Method of Lining and Cutting the Joint	112, 113
EXERCISE No. 12. — LAP DOVETAIL.	
174. Lining and Cutting	114, 115

EXERCISE NO. 13. — BLIND DOVETAIL.

175. Lining and Cutting. — 176. A Modified Form of the Joint . 115-117

EXERCISE NO. 14. — FRAME AND PANEL.

177. Panel Door Described. — 178. Making the Joint between Stile and Rail. — 179. Cutting Chamfers. — 180. Keying the Joint. — 181. Finishing the Panel. Fastening Panel to Frame. — 182. Inserting Screws. — 183. Using the Brad-Awl . . . 117-121

EXERCISE NO. 15. — FRAME AND PANEL

184. Making Joint between Stile and Rail. — 185. Plowing. — 186. Beading. — 187. Forming the Panel 121-124

PART III. — ELEMENTS OF WOOD CONSTRUCTION.

TIMBER.

188. Timber Defined. — 189. Felling. — 190. Seasoning. — 191. Shrinkage. — 192. Swelling. — 193. Warping. — 194. Effect of Shrinkage on Cross-section. — 195. Effect of Shrinkage on Length 124-129

CARPENTRY.

196. Work of Carpenter and Joiner Compared. — 197. Compressional, Tensional, and Cross-Strain Defined. — 198. Effect of Cross-Strain. Neutral Axis. Relation between the Depth of a Timber and its Resistance to Cross-Strain. — 199. Rankine's Principles concerning Joints and Fastenings 130-132

JOINTS CONNECTING TIMBERS IN THE DIRECTION OF THEIR LENGTH.

200. Lapped Joint. — 201. Fished Joint. — 202. Scarfed Joints. —
 203. Scarfed Joint for Resisting Compression. — 204. Scarfed
 Joint for Resisting Tension. — 205. Scarfed Joint for Resisting
 Cross-Strain. — 206. Scarfed Joint for Resisting Tension and
 Compression. — 207. Scarfed Joint for Resisting Tension and
 Cross-Strain 133-135

JOINTS CONNECTING TIMBERS AT RIGHT ANGLES.

208. Halving. — 209. Notching. — 210. Cogging. — 211. Mortise-
 and-Tenon Joints. — 212. Mortise and Tenon Joining a Vertical
 to a Horizontal Timber. — 213. Mortise and Tenon Joining
 a Horizontal to a Vertical Timber. — 214. Mortise and Tenon
 Joining One Horizontal Timber to Another. Tusk Tenon 136-139

MISCELLANEOUS JOINTS.

215. Oblique Mortise and Tenon. — 216. Bridle-Joint. — 217. Tie-
 Joint. — 218. Chase-Mortise 139-141

JOINERY.

219. Joinery Described 141, 142

BEADS AND MOLDINGS.

220. Beads. — 221. Use of Beads. — 222. Chamfer. — 223. Stop
 Chamfer. — 224. Moldings Described. — 225. Round Nose. —
 226. Some Typical Forms of Moldings. Fillet. — 227. Joints
 in Joinery Defined 142-145

HEADING-JOINTS, OR JOINTS UNITING PIECES IN THE DIRECTION OF
 THEIR LENGTH.

228. Square Heading-Joint. Splayed Heading-Joint 145

JOINTS UNITING PIECES IN THE DIRECTION OF THEIR WIDTH.

229. Their Office. — 230. Butt-Joint. Filleted Joint. Rabbeted Joint. Matched Joint. — 231. Glued Butt-Joint. — 232. Cleating. — 233. Side Cleats. — 234. End Cleats. — 235. Relieving Cleats from Strain 145-148

JOINTS UNITING PIECES AT RIGHT ANGLES.

236. Butt-Joint. — 237. Miter-Joint. — 238. Strengthening of Miter-Joints. — 239. Dovetail-Joints. — 240. Proportions of Mortise-and-Tenon Joints. — 241. Single and Double Tenons. — 242. Haunching. — 243. Four Tenons. — 244. Mortises and Tenons at an Angle in the Work. — 245. Modifications of Mortise-and-Tenon Joints 148-152

PANELING.

246. Panel. — 247. Frame. — 248. Joints between Panel and Frame 152-155

FASTENINGS.

249. Pins. — 250. Wedges. — 251. Blind-Wedging. — 252. Keys. — 253. Dowels. — 254. Nails. — 255. Size of Nails. — 256. Brads. — 257. Tacks. — 258. Screws. — 259. Glue . . . 155-161

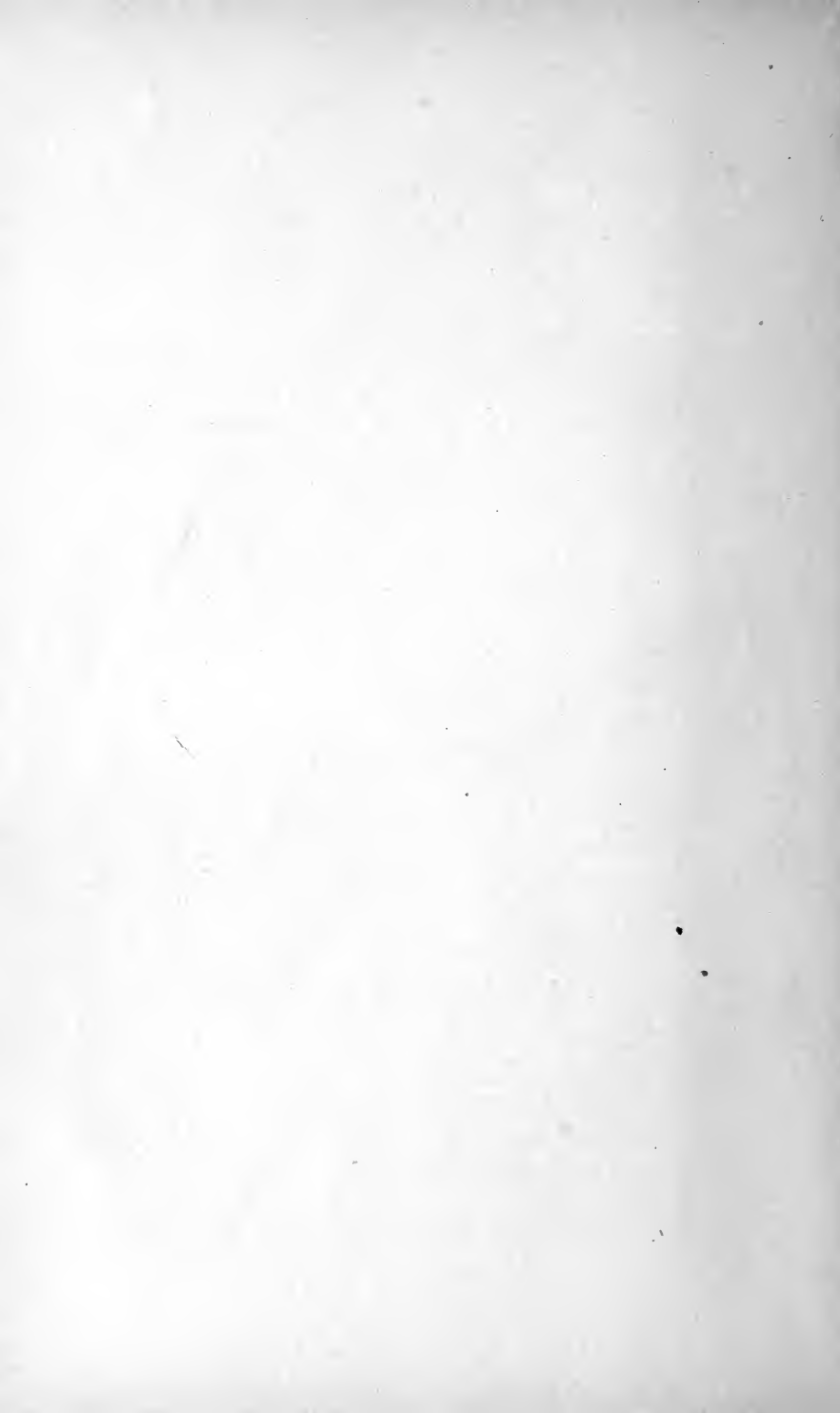

INTRODUCTION.



INTERPRETATION OF MECHANICAL DRAWINGS.

1. Most of the illustrations presented with the following chapters are in the form of Mechanical Drawings. To the novice, these may appear confusing; but careful attention to some of the principles underlying their construction will enable him readily to interpret their meaning.

A mechanical drawing, as distinguished from a perspective drawing, or picture, instead of giving all the characteristics of an object at a glance, presents them in detail, giving in one view one set of elements, in another view another set of elements, and so on, until the form of the object is accurately defined.

For example, Fig. 1 is a perspective view of an object which is represented mechanically by Fig. 2. By Fig. 1 it will at once be seen that the object represented is a cylinder. In Fig. 2 there is first presented a *plan*, showing that the object is cylindrical; and, secondly, an *elevation*, showing the height of the cylinder. From the combination of these two views, the solid may be as easily imagined as from Fig. 1, and the knowledge obtained of it is much more definite.

A perspective view of an object is that which is had by looking from some one point, as *A*, Fig. 3, while a view represented by a mechanical drawing supposes the ob-

Fig. 1

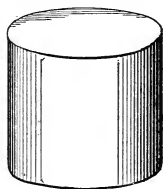

another set of

Fig. 2.



PLAN.

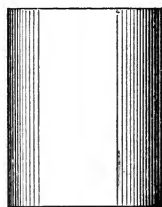

ELEVATION.

server to be looking from an infinite number of points, and always in parallel lines, as indicated by *A*, Fig. 4.

2. **A Plan** of any object represents it as it would appear if, standing on its natural base, it were looked down upon vertically, as indicated by the arrows *A*, Fig. 5. If the object, as a rectangular block, has no fixed base, any one of its faces may be taken as such.

Fig. 3

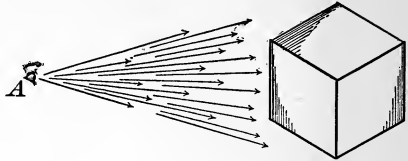

Fig. 4

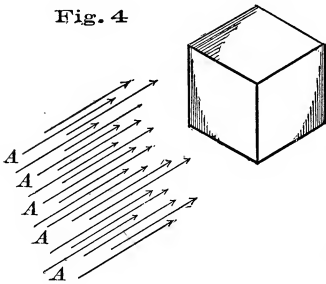
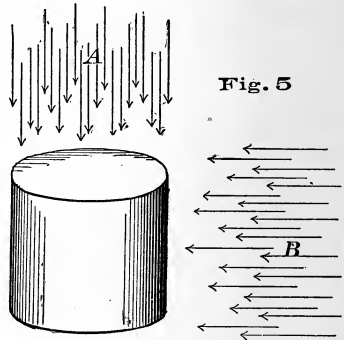

Fig. 5



3. **An Elevation** of any object represents it as it would appear if, standing on its natural base, it were looked upon in a horizontal direction, as indicated by arrows *B*, Fig. 5.

Fig. 6

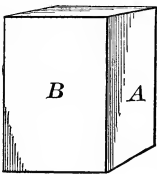
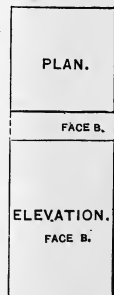

Fig. 7



The elevation is always at *right angles to the plan*. There may be several elevations of the same object, each differing from the others as the point of observation changes. For example, the plan and elevation of the object represented by Fig. 6, are usually made as shown by Fig. 7, but they may be made as shown by Fig. 8, or Fig. 9.

These angular views, indeed, cannot be avoided when the form they represent is so complicated that its faces are neither parallel, nor at right angles to each other.

Fig. 10 is a perspective view of an object which is represented mechanically by Fig. 11. It is evident that if one face of *A* is shown in the elevation, two faces of *B* will appear; if one face of *B* is shown, two of *A* will appear.

In the representation of simple objects, the plan is in some cases omitted, and two elevations employed.

These may be designated as *side elevation* and *end elevation*, which terms signify an elevation of a side and an

elevation of an end. For example, if we consider the surface *A* the base of Fig. 6, a side elevation would be equivalent to the elevation Fig. 7, and the end elevation would become equivalent to

the plan of the same figure.

4. Method of showing Parts obscured from Sight. — The outline of details, which in any view of an object are hidden, is frequently shown by dotted lines.

Thus, in Fig. 12, the general outline of the plan and elevation shows a rectangular block; if the circle in the plan is associated with the dotted lines in the elevation, it is not difficult to imagine a round hole extending through the center of the block. If the hole penetrates to only half the depth of the block, dotted lines will be placed as shown by Fig. 13; if the hole is larger at the top

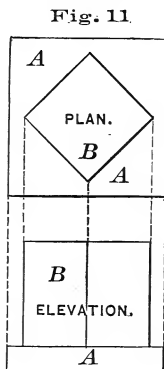
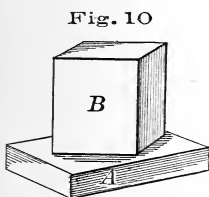
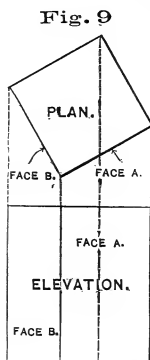
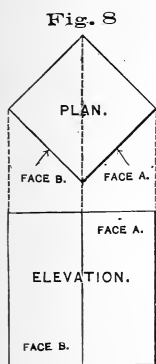

than at the bottom, the drawing will appear as shown by Fig. 14; if smaller at the top, as shown by Fig. 15. In Fig. 16 dotted

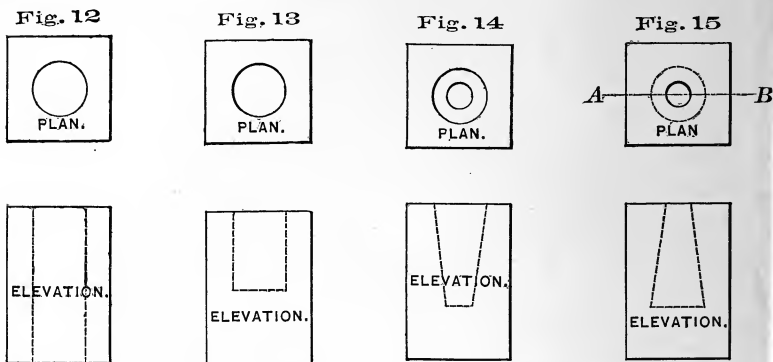

lines indicate the diameter of a bolt holding the two pieces *A* and *B* together.

5. Sections.— In complicated drawings, the use of dotted lines to indicate hidden parts is more confusing than helpful.

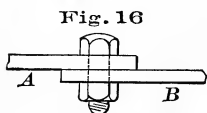

In such cases it is customary to imagine the object cut, as if it were sawed asunder, and the surface thus produced exposed. Such a surface is called a "section."

Complete sections show not only the surface produced by the cut, but the outline of other portions of the object which may be seen beyond. See lines *a, a*, Fig. 17.

Thus, section *AB*, Fig. 17, is that which would appear if the ring were to be cut on the line *AB* (Plan, Fig. 17), and the cut surface made to appear in elevation.

Section lines on a drawing show the location of sections. They are usually made in color (red or blue), or in dotted black, with a colored line on each side. Each section is designated by the letters of its section line.

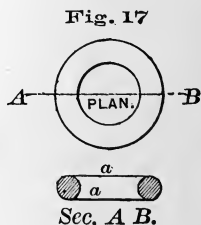

Cross-hatching is a term applied to the uniformly spaced parallel lines which are employed to indicate the cut surface of a section. See Fig. 18.

Different pieces of material appearing in the same section are cross-hatched at different angles, as in Fig. 19, which represents a cross-section of a lead-pencil; and different kinds of material are frequently indicated by cross-hatching in different colors.

Fig. 18

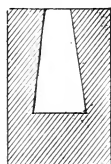

SECTION A B, FIG. 15.

Fig. 19



Incomplete sections show only the cut surface, to the exclusion of all other portions of the object. It is common to place such sections on the section lines, and omit the letters. See Fig. 20.

A single view of a symmetrical object may be made partly in section, and partly in elevation, as in the drawing of the goblet, Fig. 21.

6. Broken Drawings. — To economize space in representations of simple objects, a

Fig. 20

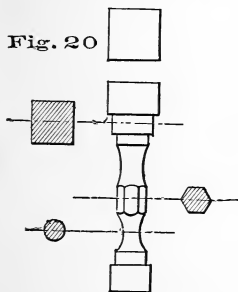

portion of the drawing is sometimes omitted. In such cases, that which is given indicates the character of the omitted portion, and the dimension figures show its extent. An example is given in Fig. 22.

Fig. 21

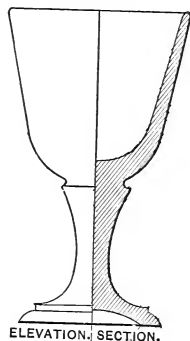

ELEVATION, SECTION.

7. Scale. — Drawings are made either “full-sized” or “to scale.” A full-sized drawing is one in which every dimension agrees exactly with the similar dimension of the object it represents. A drawing to scale is one in which every dimension bears the same fractional relation to the similar dimension of the object it represents. When a drawing is $\frac{1}{2}$ th the size of

the object, it is said to be on a scale of $\frac{1}{2}$ inch to the foot, or, as frequently written, $\frac{1}{2}$ in. = 1 ft. ; if $\frac{1}{6}$ th the size, as 2 in. = 1 ft., and so on. The scale 6 in. = 1 ft. is often expressed as "half size."

8. Dimensions.—The various dimensions of an object represented are shown on the drawing by appropriate figures, which express feet when followed by ', and inches when followed by ". Thus 2' should be read as two feet, and 2" as two inches. 12' 7 $\frac{3}{4}$ " is the same as twelve feet and seven and three-quarters inches.

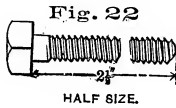

The figures always show the dimensions of the thing represented ; they do not agree with the dimensions of the drawing except when the latter is full-sized. See dimension figures in Fig. 23.

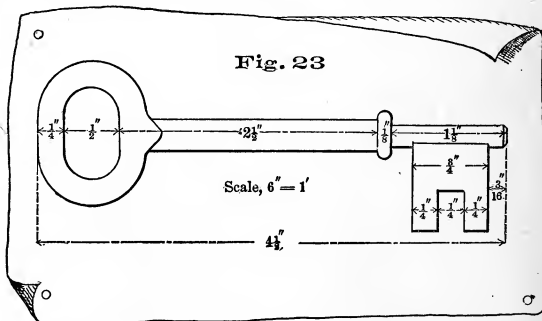

Dimension lines.—Dimension figures are always placed on, or near, lines along which they apply. In drawings these lines are usually in color (red), but may be dotted black, as in Fig. 23. When convenient, they are placed within the outline of the drawing ; but if the drawing is small or crowded, they are placed at one side, and are connected with the parts they limit by perpendicular, colored or dotted lines. Two arrow-heads, one on each side of the dimension figure, locate the points between which it applies. Several dimensions may be given on the same line, each being limited by its own arrow-heads.

PART I.



BENCH TOOLS.

9. **Bench.** — A simple form of bench is shown by Fig. 24. Its length A may vary from 6' upwards, according to the length of work to be done. Its height B should also be regulated by the character of the work—high for light work, and low for heavy—as well as by the height of the person who is to use it. Carpenters' benches are usually about 33" high, while those of cabinet and pattern makers are from 2" to 4" higher.

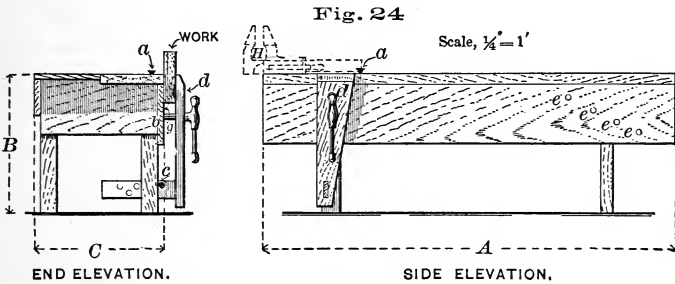

The surface of the bench, particularly of the thick plank that forms the outer edge of it, should be perfectly flat—a true plane. When in use, care must be taken to protect it from injury. It should never be scarred by the chisel or cut by the saw. If oiled and shellaced, it is likely to be better kept.

10. **The Bench-Stop** a is intended to hold the work while it is being planed. It may be simply a piece of wood about 2" \times 2", projecting through a mortise in the top of the bench ;

but it is far better to have some form of iron fitting, many of which are supplied by the trade. The characteristics of all of them are well illustrated by the one shown in Fig. 25. The frame *A* is let into the bench even with its surface. The hook *C* is held in position at any height above the bench by the action of the screw *B*. *C* may be fastened even with the surface of the bench, or removed entirely.

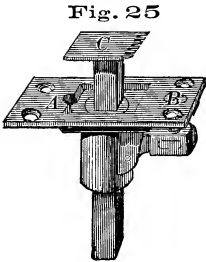

11. The Vise *d*, Fig. 24, is of a form that, for general purposes, has long been in use. To hold the work well, the jaw *d* should be as nearly as possible parallel to the face *g*, against which it acts. If it is not parallel, the space between should

Fig. 26

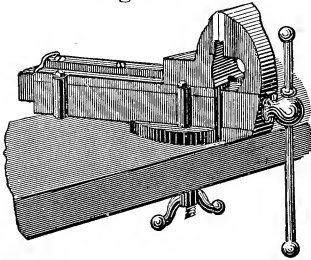

be less at the top than at the bottom — an arrangement which insures a much better grip upon the work than the opposite conditions. Adjustments for parallelism are made by changing the pin *c* from one hole to another. There are various mechanical appliances for preserving automatically the parallelism of this vise, but none are in common use. Iron vises can be had which are adapted to the same uses as the one just described; they maintain their parallelism, and are easier and more perfect in action.

An iron bench vise, such as is shown by Fig. 26, is extremely useful for small work, and, if expense is not to be considered, should supplement the vise *d*, in which case it may be located on the bench at *H*.

The holes, *e*, in the bench are for the reception of a plug, which may be used to support one end of a long piece of work while the other end is held by the vise.

12. **A Bench-Hook**, Fig. 178, applied to the bench as shown by Fig. 167, provides a stop to prevent work from sliding across the bench. The flat faces which rest on the bench and receive the work, should be true planes and parallel. A length of from 14" to 16" is convenient, though bench-workers frequently have several of different lengths.

13. **Trestles**, or "horses," are used in various ways to support material, and also to take the place of the bench when large pieces of material are to be operated upon. A convenient form is shown by Fig. 27.

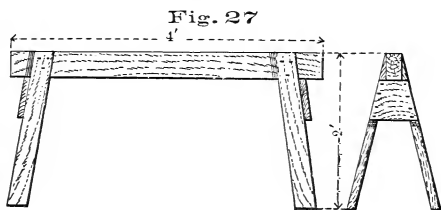

MEASURING AND LINING APPLIANCES.

14. **Early Standards of Length.**—To meet the earliest need of units of measure, it was natural to adopt the means nearest at hand, and common consent, no doubt, brought into use the pace, the forearm, or cubit, the foot, the hand, the nail, etc. These were certainly convenient enough, for wherever he might go, every individual carried his units of measure with him. Variations in their length, however, were inevitable, and many attempts were made to reduce them to a standard. An old English statute, the substance of which has descended to American arithmetics of modern date, enacts "that three barleycorns, round and dry, make an inch, twelve inches make a foot, three feet a yard, etc. ; and there seems to be no doubt that this mode of obtaining a standard was actually resorted to. But setting aside the objection due to the varying size of the individual grains,—unless the average of a large number be taken,—it is so difficult to know how much of the sharp end of a grain of barley must be removed to make it 'round,' that

the definition is not of much value. Nevertheless, in spite of numerous attempts at legislation on the subject, this, down to the year 1824, was the only process by which the standard yard of this country [England] could, if lost, be legally recovered."¹

Previous to the institution of a national standard of length in Great Britain, influential men and prominent societies provided themselves with so-called standards, which were accepted and used in different localities. By comparison with many of these, the present standard of length was made, and its length defined by law as the British standard yard. From this, about fifty copies have been made. Two of these copies were in 1855 sent to the United States, and have since been in the keeping of the Coast Survey. They are described as follows:—

15. "Each standard of length is a solid bar 38 inches long and 1 inch square, in transverse section. One inch from each extremity a cylindrical well, one-half inch in diameter, is sunk one-half inch below the surface. At the bottom of the wells, in each bar, is a gold pin about 0.1 inch in diameter, upon which are drawn three transversal and two longitudinal lines. The wells are protected by metal caps. The length of one English yard at a specified temperature is defined by the distance from the middle transversal line in one well to the middle transversal line in the other, using the parts of those lines which are midway between the longitudinal lines."²

16. **The United States Standard of Length.** — "The standard yard of Great Britain was lawful in the colonies before 1776. By the Constitution of the United States the Congress is charged with fixing the standard of weights and measures, but no such enactment has ever been made by Congress, and

¹ Shelley's "Workshop Appliances."

² Report of the United States Coast Survey, 1877, Appendix No. 12.

therefore that yard which was standard in England previous to 1776 remains the standard yard of the United States to this day."¹

17. "The Troughton Scale is a bronze bar with an inlaid silver scale, made for the survey of the coast of the United States by Troughton, of London. The bar is nearly 86 inches long, $2\frac{1}{2}$ inches wide, and one-half inch thick. A thin strip of silver, a little more than 0.1 inch wide, is inlaid with its surface flush with the brass, midway the width of the bar. It extends the whole length of the bar, save where it is interrupted by two perforations, one near each end. Two parallel lines about 0.1 inch apart are ruled longitudinally on the silver. The space between them is divided transversely into tenths of inches.

"The zero mark of the graduations is about 3.2 inches from one end of the bar. Immediately over it is engraved an eagle, surmounted by the motto, *E Pluribus Unum*, and thirteen stars. Below the 38 to 42-inch divisions is engraved 'Troughton, London, 1814.' The bar is also perforated by a hole above the scale and near the 40-inch division, and by one below it, between the words 'Troughton' and 'London.' . . .

"The yard of 36 inches, comprised between the 27th and 63d inch of the Troughton scale, which was found by Hassler's comparison to be equal to the average 36 inches of the scale, is the actual standard yard of the United States, having been adopted by the Treasury Department as such in 1832, on the recommendation of Mr. Hassler."²¹

18. **Rules** are measuring strips, and are usually made of boxwood. Their size is expressed by their length in inches or feet, as a "6-inch rule," a "2-foot rule."

For convenience, they are made to fold,

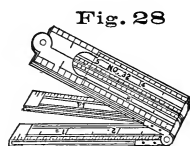

¹ Report of the United States Coast Survey, 1877, Appendix No. 12.

² Hassler was the first superintendent of the United States Coast Survey.

and one is said to be "two-fold" when made of two pieces, "four-fold" when made of four, and "six-fold" when made of six pieces. Fig. 28 shows a four-fold rule.

To preserve the rule from wear, the better class are "bound" by a strip of brass which covers each edge; others are "half-bound," having only one edge covered; and still others are "unbound," having no edge protection.

Carpenters' rules are usually graduated to eighths of inches on one side, and to sixteenths on the other. Besides the regular graduations, other numbers are frequently represented; but their purpose is so varied that their interpretation cannot be given here.

19. The Framing-Square, Fig. 29, as its name implies, is intended primarily for use in framing, and would seem to belong to the builder rather than to the bench-worker; but its range of usefulness makes it valuable to any worker in wood.

All but the very cheapest are of steel, and many are nickel-plated. The nickel prevents rust, and gives clearness to the lines and figures. The figures of the graduations along the several edges, begin at the angle and extend to the ends of the legs. In addition to these, there is on one side a line of figures beginning at the end of the long leg and extending to the angle. On the reverse side, represented by Fig. 29, there is on the long leg a board-measure table, and on the short leg a brace-measure table.

20. The Board-measure Table. — Lumber is sold by the square foot, and the value of the table lies in its giving the area of a board, or of any surface, in square feet, when its length in feet and its breadth in inches are known.

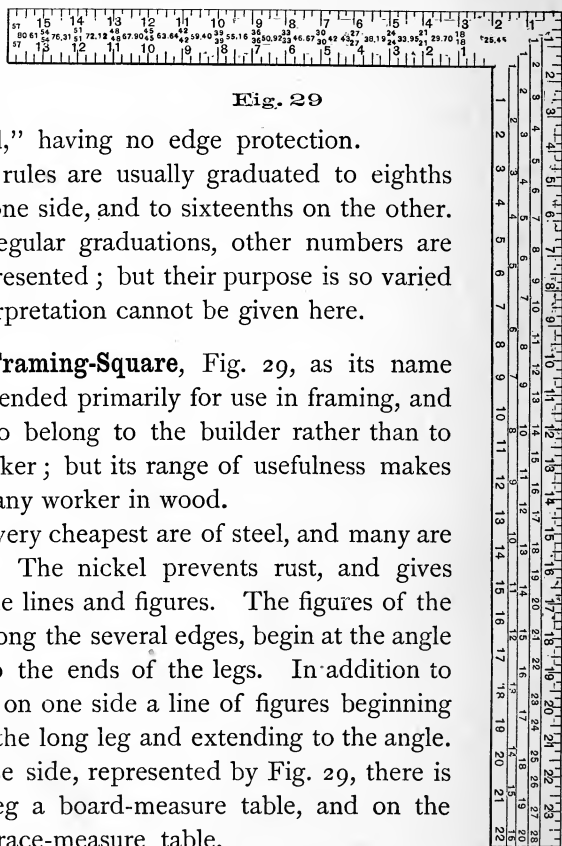

Fig. 29

The figures that belong to the outside graduations, 1, 2, 3, and so on up to 24, are employed to represent the width of the board to be measured, and all the lengths included in the table are given in a column under the figure 12 belonging to the outside graduations. On this square, Fig. 29, they are 14, 10, and 8. To find the surface of any board, first look in the column under 12 for a number representing its length, and having found it, run the finger along in the same line until it comes under that figure of the outside graduations that corresponds to the board's width. The figure nearest the finger in this line represents the area of the board in feet.

Example 1.—How many square feet are there in a board 10' long and 7" wide?

Under 12 of the outside graduations, in Fig. 29, the 10 is in the second line, and the figure in this line most nearly under 7 of the outside graduations, is 6, which represents the area required, in feet.

Example 2.—What is the surface of a board whose length is 8' and whose width is 21"?

As in Example 1, look under 12 of the outside graduations for 8; in this line, under 21 of the outside graduations, will be found the 14 which represents the area required.

The reason that the column under 12, forming, as it does, a part of the body of the table, is taken to represent the length, will be clear when it is remembered that any board 12" wide will contain as many surface feet as it contains linear feet; that is, a board 12" wide and 14' long will have an area of 14 square feet. The figures given under 12 correspond to the usual length to which lumber is cut, and on most squares they are 8, 10, 14, 16, and 18; and, since the figure representing the area differs from the figure representing the length only because the width varies, we must go to the right or the left of the column under 12, when the width is greater or less than 12.

21. **The Brace-measure Table** gives the length of each side of several right-angled triangles. A brace in carpentry is a

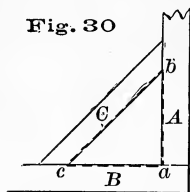

timber inserted diagonally between two other timbers which usually are at right angles to each other. If it is required to insert a brace C between A and B , Fig. 30, its length may be determined by using the table on the framing-square, which, within certain limits, gives the carpenter the length of C when the

lengths A and B are known.

Taking the group of figures nearest the end of the short leg for the illustration, suppose A (length ab) = $57''$ and B (length ac) = $57''$, then C (length bc) = $80.61''$. By the next group, it will be seen that if A and B each equal $54''$ or $54'$, C will equal $76.31''$, or $76.31'$. The two figures representing the length of the two short sides of the triangle, are always given one above the other, and the figure representing the length of the third side, to the right of the other two.

22. **A Try-Square** is shown by Fig. 31. The beam A in this case is of wood, faced by a brass strip C to protect it from wear. The blade B , at right angles to the beam, is of steel. The graduations on the blade, together with its thinness, make this square more convenient for short measurements than the rule.

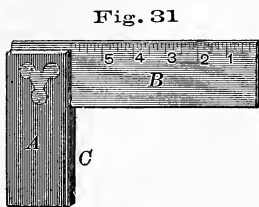

Try-squares are made from $4''$ to $12''$, their size being expressed by the length of the blade.

23. **The Bevel**, often improperly called "bevel-square," is made up of parts similar to those of the try-square,

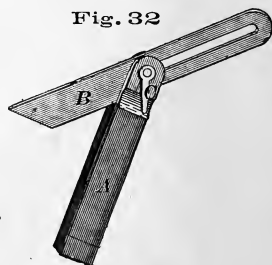

as will be seen by Fig. 32. The blade is adjustable to any angle with the beam; the thumb-screw *C* fastens it when set.

The size of a bevel is expressed by the length of its beam in inches.

24. "**Miter-Squares**" derive their name from the purpose they are intended to serve. A "miter" in construction is one-half of a right angle, or an angle of 45 degrees. In the "miter-square" the blade, as in the try-square, is permanently set, but at an angle of 45 degrees, as shown by Fig. 33.

The bevel, while neither so convenient nor so accurate, is often made to answer the purpose of the "miter-square."

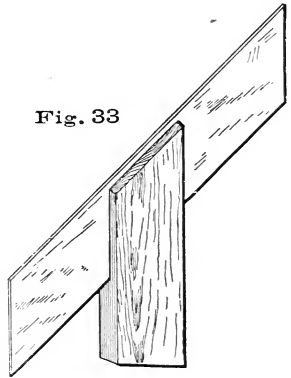

Fig. 33

25. A **Combination Try-and-"Miter" Square** is shown by Fig. 34. This, while

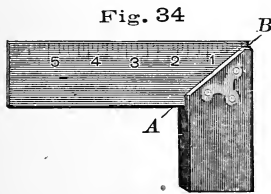

Fig. 34

perfect as a try-square, is transformed into a "miter-square" when the face of the beam *AB* is placed against the work-

ing-face (119) of the material.

26. **Dividers** are much used in spacing and in laying off circles and arcs of circles.

The form shown by Fig. 35 is known as "arc and set-screw dividers." The two points are held at any desired distance from each other by the action of the set-screw *A* upon the arc *B*. In setting, the final adjustment may be made more

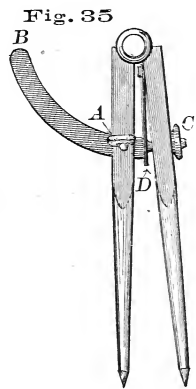
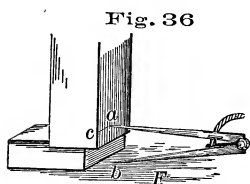

Fig. 35

delicate by use of the thumb-nut *C*, which, acting in opposition to the spring *D*, shortens the arc *B* or allows the spring to lengthen it, as may be required.

27. Scribing with Dividers: *Example 1.* — The four legs of a table are of unequal length, and prevent it from standing even. Scribe the legs to length.

First, by means of blocks or wedges under the shorter legs, make the top of the table stand parallel to some plane surface, as a bench top, or even the floor if it is in good condition, either of which may be designated as *F*, Fig. 36. Set the dividers equal to or greater than the height of the thickest blocking, so that while one point, *a*, touches the leg, the other, *b*, will rest upon *F* in the same vertical line. Move the dividers, keeping *b* on *F*, and producing by *a* a line on the leg, as *ca*, which, if the dividers are properly handled, will be parallel to the surface *F*. Without changing the dividers, mark at least two adjoining faces on each leg, and cut the legs to line.



It is evident that lines thus scribed will all be at an equal distance from the surface *F*; and the table top, having been

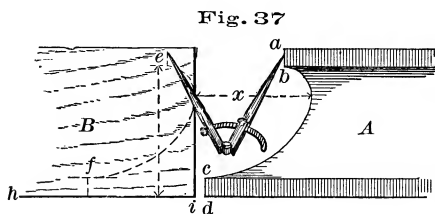

made parallel to *F*, it follows that the lines scribed are parallel to the top, or that the length of the four legs, as defined by the lines, is the same.

Example 2. — It is required to fit the end of a board *B* to the outline *abcd* of *A*, Fig. 37. Place the board in the position shown, and set the dividers at a distance equal to *x*. With one point at *a* and the other at *e*, let them be moved together, one following the outline *abcd* which the other produces on *B*,

as shown. Cut to line, and the board will fit. When sharp angles, as at f , enter into the outline, greater accuracy will be attained if the point f is located by measuring from the base line hi .

28. Combining Measuring Appliances. — To find the hypotenuse of a right-angled triangle when the other two sides are known, use the rule and framing-square, as shown by Fig. 38. Suppose in Fig. 30 the length $ab = 5\frac{1}{2}"$, and the length $ac = 9\frac{1}{2}"$; to find the length bc , apply one end of the rule to the $9\frac{1}{2}"$ mark on one leg of the square, and bring its edge to coincide with the $5\frac{1}{2}"$ mark on the other leg, as shown by Fig. 38. The reading of the rule where it coincides with the $5\frac{1}{2}"$ mark, or $10\frac{7}{8}"$, will be the length bc . The length thus found will be sufficiently accurate for many purposes. If the distance to be measured is in feet, imagine every inch on the square to be equal to a foot, and read the result in feet.

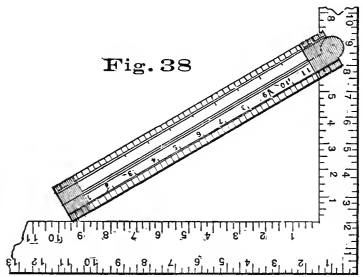

Fig. 38

If the proportions of the triangle are very large, the figure may be drawn at full size on the shop floor, and the extent of each part determined by direct measurement.

29. Setting the Bevel. — To set the bevel at a miter (an angle of 45°), place the beam against one leg of the square and adjust the blade so that it will agree with equal distances on both legs, as $4"$ and $4"$, Fig. 39. Any distance may be taken, but it must be the same on both legs.

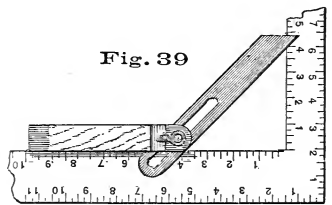
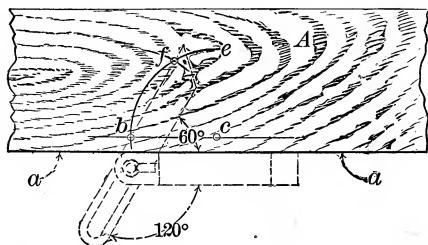

Fig. 39

The carpenter frequently describes an angle to which the bevel may be set as "1 in 2" or "1 in 4," by which is meant that while the beam is applied, as shown by Fig. 39, the blade corresponds to the 1" mark on one leg, and the 2" mark on the other; or to the 1" mark on one leg, and the 4" mark on the other.

30. **To set the Bevel at an Angle of 60, and of 120 Degrees.** — In Fig. 40 the board *A* has a jointed edge *a*; at any distance from *a*, gauge a line *bc*. From any point on *bc*, with any radius, use the dividers to strike the arc *bc*; with same radius, strike from *b* the arc *f*. Place the beam of the bevel against face *a*, move blade till it co-

Fig. 40



incides with the points *b* and *f*, and the bevel is set at an angle of 60 degrees with one side of beam, and 120 degrees with the other. 60 degrees is the measure of the angle between any two faces of an equilateral triangle, and 120 degrees, of the angle between any two faces of a regular hexagon; for these reasons, the bevel set at these angles is often of use in construction.

31. **To set the Bevel at any given Angle.** — If an attempt is made to set the bevel directly from lines on paper, it will be found difficult to determine when the tool agrees with the drawing. It is better to transfer such an angle to a board, from the working-edge of which the bevel may be set. Thus, if it is required to set the bevel at the angle *abc*, Fig. 41, a board, as *A*, should be lined as follows:

from the working-edge gauge the line *a'b'*; with the dividers,

Fig. 41

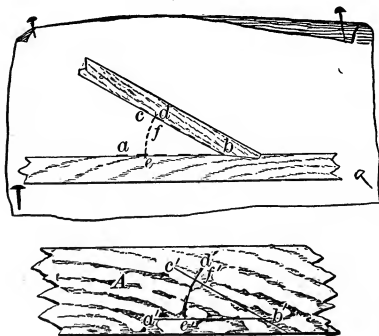

from the working-edge gauge the line *a'b'*; with the dividers,

at any convenient radius, describe from b' the arc $e'd'$; with the same radius describe from b the arc ed ; set the dividers so that with one point on e the other will fall on f , and lay off this distance on $e'd'$, locating f' ; connect b' and f' ; the angle $a'b'c'$ will be equal to abc . As $a'b'$ is by construction parallel to the working-edge of the board, the angle between the working-edge and $b'c'$ is equal to the angle abc . If, then, with the beam of the bevel on the working-edge, the blade is made to coincide with $b'c'$, the bevel will be set at the angle abc .

32. **Marking-Gauges.**—Fig. 42 shows the usual form of a marking-gauge. The steel point, or “spur,” e , should be filed to a narrow edge, so that it will make a sharp line.

The graduations along the length of the beam B , are not to be depended on unless it is known that the zero line is exactly opposite the spur. When the zero mark and the spur do not agree, as is frequently the case, it is necessary in setting the gauge to measure from the head A to the spur e . A when set, is prevented from moving on B , by the screw C .

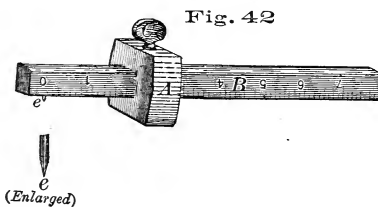

33. **A Mortise-Gauge**, shown by Fig. 43, has two spurs, a being fastened to the beam, and b to a brass slide which works in a groove in the beam. The spur b may be set at any distance from a by the action of the screw c . The gauge may, therefore, be set to line both sides of a mortise at the same time.

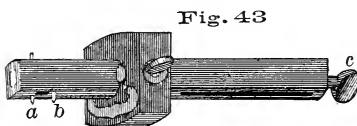

34. **Panel-Gauges**, Fig. 44, are for use in making lines at a considerable distance from the working-edge.

The length of the head *A* is sufficiently increased to receive good support from the working-edge, which guides it.

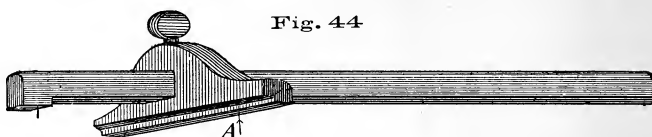

Fig. 44

35. **Cutting-Gauges**, having a long, thin blade in the place of the usual spur, are in form similar to that shown by Fig. 42. They are useful in cutting strips of thin material.

36. **Chalk-Lines** are very seldom used in bench work, but are often convenient in applying such work to larger structures. The cord used in lining should be as small as is consistent with strength. On most surfaces blue chalk is more easily seen than white.

37. **The Scriber**, as known to the trade, takes a variety of forms, from that of an awl to that of a peculiar short-bladed knife. A well-kept pocket knife of convenient size will be found a good substitute for any of them.

38. **The Pencil** used in lining on board surfaces should be soft, and kept well-pointed by frequent sharpening.

CHISELS AND CHISEL-LIKE TOOLS.

39. **Firmer-Chisels** have blades wholly of steel. They are fitted with light handles and are intended for hand use only.

Fig. 45



40. **Framing-Chisels** have heavy iron blades overlaid with steel. The handles are stout and are protected at the end by ferrules. This chisel is used in heavy mortising and framing, and is driven to its work by the mallet.

Compare Fig. 45, which shows a firmer-chisel, with Fig. 46, which shows a framing-chisel.

Fig. 46



The size of chisels is indicated by the width of the cutting edge, and varies from $\frac{1}{8}$ " to 1" by sixteenths, and from $1\frac{1}{4}$ " to 2" by fourths.

41. A **Corner-Chisel** is shown by Fig. 47. Its two cutting edges are at right angles to each other, and this form renders

Fig. 47

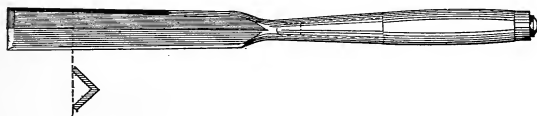

it useful in making inside angles, as, for example, the corners of a mortise. Its handle is like that of a framing-chisel. The size of a corner-chisel is indicated by the length of one cutting edge.

42. **Gouges** have blades that, throughout their length, are curved in section, as shown by Fig. 48. When the bevel forming

Fig. 48

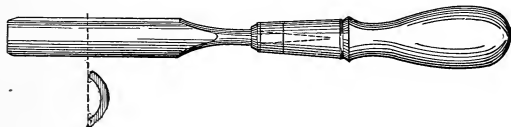

the cutting edge is on the concave side, they are called "inside gouges"; when on the convex side, "outside gouges." For general purposes the outside gouge is most convenient, and the carpenter, with his limited facilities for the care of tools, can more easily keep it in order. The size of a gouge is indicated by the length of a straight line extending from one extremity of the cutting edge to the other.

43. Handles for chisels, gouges, and similar tools, are of two general classes, light and heavy; the former are intended principally for hand use, and are shown in connection with the firmer-chisel and gouge; the latter, which are re-enforced at the end by a ferrule that they may withstand blows from the mallet, are illustrated in connection with the framing-chisel and the corner-chisel.

Handles may be shank-fitted, like the one shown by Fig. 48, or socket-fitted, as shown by Fig. 47. The better class of tools have socket-fitted handles.

44. **The Drawing-Knife**, shown by Fig. 49, is in reality a wide chisel, though it is quite different from a chisel in form.

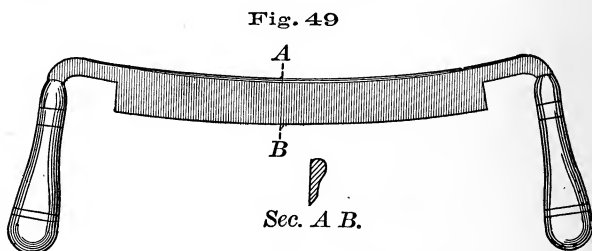

The handles are so attached as to stand in advance of the cutting edge, which is drawn into the work, instead of being pushed into it, as is the case with a chisel. The drawing-knife is very effective on narrow surfaces that are to be considerably reduced. The size is indicated by the length of the cutting edge.

45. **The Action of Cutting Wedges.** — Every cutting tool is a wedge more or less acute. In action it has two operations to perform: first, cutting the fibers of the wood; and, secondly, widening the cut in order that the tool may penetrate into the material, and thus allow the cutting edge to go on with its work. To widen the cut, the fibers of the wood must be pressed apart (the wood split), or the fiber ends crushed, or the material on one side of the wedge must be bent, thus forming a

shaving. It is evident that a unit of force tending to drive the edge forward will, under like conditions of material, always result in the same amount of incision. But much less force is required to carry the tool forward when the cutting edge is just entering the material, than when it has advanced to a considerable depth, and, hence, it is fair to assume that this difference is due solely to the resistance that the material offers in opening to make way for the tool, this resistance increasing as the tool goes deeper. The resistance offered to a tool by a bending shaving, therefore, may be many times greater than that offered to the cutting edge by the wood fibers.

An obtuse-angled wedge will cut as easily as a more acute-angled one, but the more obtuse the angle is, the more abrupt must be the turning of the shaving; and since the latter factor is the more important, as regards the absorption of force, it follows that the more acute the cutting edge is, the more easily it will accomplish its work.

46. Angle of Cutting Wedge in Chisel and Gouge. — The acuteness of the angle cannot be defined in degrees since, being limited only by the strength of the steel, it must vary as the duty required of it varies. For example, a more acute angle may be used in soft than in hard wood; again, a chisel handled as shown by Figs. 147 and 148, is not so severely strained as when used in the manner illustrated by Fig. 149. If the maximum degree of delicacy were insisted on under every condition of use, the cutting edge would need to vary with every turn of the chisel, and almost with every shaving it cuts. This would be impracticable, and wood workers reduce all these requirements to a single principle which may be expressed as follows: let the cutting edge be as acute as the metal will allow without breaking, when fairly used. A little experience with a given tool is the readiest means of finding the angle suited to a given class of work. Carriage makers,

who work almost wholly in hard woods, are in the habit of using what pattern makers, who work principally in soft woods, would style blunt chisels.

47. Grinding.— A new chisel, or one that has become considerably dull, must be ground. With the handle of the chisel

Fig. 50

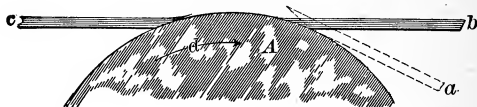

in the right hand, and the fingers of the left hand resting on the blade near its cutting edge, apply the chisel to the stone, Fig. 50, as shown by the dotted outline *a*, and then raise the right hand until the proper angle is reached, a position indicated by the full outline *b*. See that there is a good supply of water, and, as the grinding progresses, move the tool gradually from one side of the stone to the other.

Assuming that the stone is in fairly good order, the tool should be applied relative to its motion, in the manner shown by *a* and *b*, Fig. 50, the motion being in the direction of the arrow *d*. If the stone is not round or does not run true, there is danger that the cutting edge may dig into it, to the injury of both stone and tool. Under such conditions, it will be best for the operator to move round to the other side, and hold the tool in the position indicated by *c*. The first position is preferable, chiefly because of two reasons: first, the tool may be held more steadily; and, secondly, there is less tendency toward the production of a "wire edge." As the extreme edge becomes thin by grinding, it springs slightly away from the stone, and allows the chisel at points still farther from the edge to become thin, thus resulting in an extremely delicate edge which must be removed before the tool can be made sharp. In the effort to remove this wire edge, it frequently breaks off farther back than

is desired, and the process of whetting is prolonged. With the chisel held at *c* (instead of *b*, the proper position) the direction of the motion relative to the tool aggravates this tendency of the light edge to spring away from the stone.

The grinding process is complete when the ground surface reaches the cutting edge — a condition readily determined by holding the tool to the light. If it is still dull, there will be a bright line along the cutting edge. When this line has disappeared, the tool is as sharp as it can be made by grinding, which, if persisted in, will only result in a wire edge. The action of the grindstone, however, is too severe to produce a good cutting edge, and the chisel, after being ground, must be whetted (107-110).

48. To whet the chisel, apply it to the oilstone *A*, Fig. 51, in the position shown by the dotted outline *b*, and as it is moved back

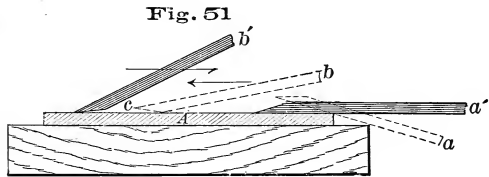

and forth along the length of the stone, as indicated by the arrows, gradually bring it to the position shown by *b'*. That is, the angle between it and the stone is to be increased until the cutting edge *c* comes in contact with the stone; this position can be recognized by the sensation imparted to the hand, and the behavior of the oil with which the stone is lubricated. At first thought, it may seem that the bevel *ab*, Fig. 52, which was produced by the grinding, should be maintained in whetting; but to do this would require so much time that one corresponding very nearly to *ab*, as *cd*, is taken.

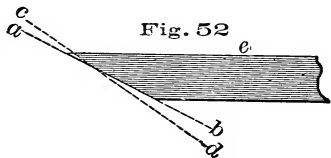

Great care is necessary on the part of one unskilled to avoid giv-

ing the tool a rocking motion on the oilstone ; if this is indulged in, the edge will appear rounded, as shown by Fig. 53, and will be no sharper than if it had the form indicated by the dotted outline

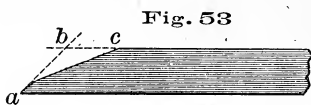

abc. When sufficiently whetted, the cutting edge, if held to the light, will show a dull, grayish hue. If a bright line appears along the edge, it is not yet sharp. The whetting turns a light wire edge over on the flat face, an exaggeration of which is shown by *a*, Fig. 54. This cannot always be seen, but may be detected by the finger ; it is removed by a single stroke of the blade with the flat face on the

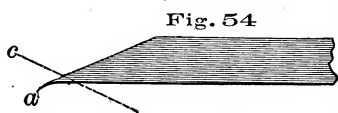

stone, as shown by *a'*, Fig. 51. It is necessary, however, that every precaution be taken to prevent the production of a bevel indicated by the dotted line *c*, Fig. 54, and opposite that already existing. To guard against this, the chisel should be applied to the stone in the manner illustrated by the outline *a*, Fig. 51 (III-115).

A tool must be whetted often enough to keep the edge in good condition ; it is dull whenever it fails to cut well. When, by frequent whetting, the whetted surface becomes so broad as to require considerable time in the production of the edge, it should be reground, and the process just described repeated.

This method of sharpening the chisel will, in general, apply to the gouge, drawing-knife, and all similar tools.

SAWS.

49. The efficiency of any saw is measured by the amount of force it absorbs in making a given cut or "kerf." For example, if one saw severs a 4" x 4" timber with half the force required by another, it is evident that the second saw is only one-half as efficient as the first. Almost every element that enters into

saw construction has its effect on the efficiency of the tool. Chief among them is the thickness of the blade, which, of course, determines the width of the kerf; for a wide kerf will require the removal of more material than a narrow one, and the force absorbed in each case must bear some relation to the amount of material removed. In recognition of this fact, the people of some eastern countries use saws designed to cut when drawn towards the operator, a method of handling that allows great thinness of blade — too great to stand the thrust by which our saws are driven into the work. But the result is that the Chinese saw, for example, which is represented by Fig. 55, accomplishes its work with remarkable ease. The shape of such a saw, however, and the awkward manner of applying force to it, probably more than neutralize the advantage gained from its delicacy, although in the abstract, the thinner the blade the better the saw.

Fig. 55



50. The form of our own saws is not the result of chance, but, on the contrary, has been developed after a careful study of the conditions under which they are required to work. Other things being equal, pushing a saw gives better results than pulling it. Under a thrusting force, it is found necessary to make the blade sufficiently thick and strong to resist bending tendencies, but with no surplus material to add unnecessary weight. In view of these facts the outline of the blade is tapered, as shown by Fig. 56. The blade is thicker also at the handle than at the point. To assist in giving it clearance in

Fig. 56

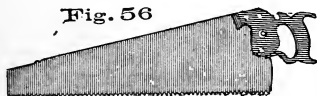

Fig. 57



the kerf, it is tapered from the teeth to the back. This difference in thickness is accomplished in the process of manufacture,

by grinding the rough blade after it has been hardened. Imperfections left by the hardening or the grinding process, may be detected in the finished saw by bending the blade, as shown by Fig. 57. If it is uniformly ground and hardened, the curve will be regular as shown; if it is thick in spots, or if it varies in hardness, the curve will be uneven, as indicated by the dotted line.

51. Set.—The thinning of the blade back from the cutting edge will not, in most cases, prevent the sides of the kerf from pressing against the saw. To meet this difficulty, the saw teeth are bent—one to one side, the next to the other side—so as to make the width of the kerf greater than the thickness of the blade. The amount of such bending, or “set,” as well as its uniformity, can readily be seen by holding the saw to the light with the back of the blade next the eye; it will then appear as

Fig. 58



shown by Fig. 58.

In very hard material the sides of the kerf are left smooth and even, and scarcely any set is required; sometimes even none. But if the material is soft and spongy, the fibers spring away from the advancing teeth, and then come back again on the blade after the teeth have passed; hence, a large amount of set is required. For most purposes at the bench, however, the set is sufficient when it can be easily and clearly seen.

52. Size of Saw Teeth.—For proper action, each tooth should begin to cut when it enters the work, and continue cutting until it leaves the kerf, and, since the space in front of each tooth must contain the material removed by it, the capacity of the space must be increased in those saws which are required to work through a considerable depth of material. A two-handed cross-cutting-saw for logs, therefore, has the teeth widely placed, thus making the intervals large.

In panel-saws, such as are used at the bench, except in spe-

cial cases, the space is of the same size and form with the tooth. When the spaces are large, the teeth must be large, and, since the size of the spaces has a direct relation to the amount of material removed, it may be said that the size of the teeth depends on the size of the material in which the saw is to work.

The size of saw teeth is expressed by the number contained in an inch. Thus "6 teeth" means that the distance from one point to another is $\frac{1}{6}$ ".

53. Ripping-Saws and Cross-cutting-Saws.—A ripping-saw is one that is used in cutting with the grain of the wood, as on the line *ab*, Fig. 59. A cross-cutting-saw is intended for use at right angles to the grain, as indicated by *cd*, Fig. 59. An oblique kerf, such as is shown by *ef*, Fig. 59, may in soft wood be cut with the ripping-saw, which will work faster than the cross-cutting, but the work will be more smoothly done by the latter. A large knot in the course of the ripping-saw may make it best to substitute the cross-cutting-saw until the knot is passed through, after which the ripping-saw may be used again. A cross-cutting-saw for the bench should have

Fig. 59

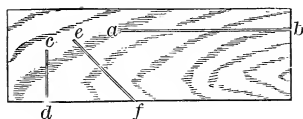
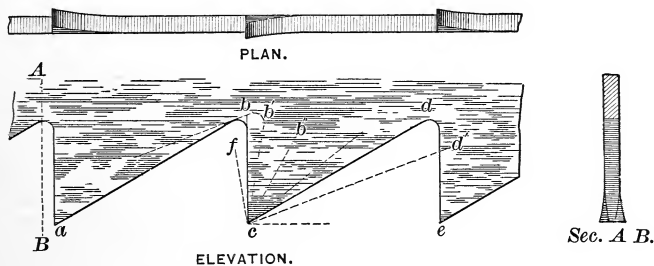

Fig. 60



a 22" or 24" blade with $7\frac{1}{2}$ or 8 teeth to the inch; a ripping-saw should have a 24" or 26" blade, with 6 or $6\frac{1}{2}$ teeth.

54. **The Teeth of Ripping-Saws.** — Fig. 60 shows a plan, elevation, and section of three teeth as they are usually made for a ripping-saw. The following paragraphs present a consideration of the action of an individual tooth.

All wood is fibrous, and any tool which is to produce a cut along the length of the fibers, as the saw kerf *ab*, Fig. 59, must, at each period of action, take something from the ends of such

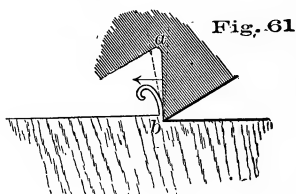

Fig. 61

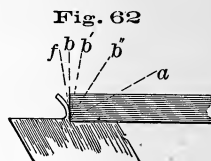

Fig. 62

fibers as may lie in the path of the proposed opening. In fulfilling this condition, the action of a ripping-saw's tooth is not unlike the action of a chisel when used as shown by Fig. 149. Each tooth in its turn removes its share from the fiber ends over which it passes, just as the chisel at every change of position takes its slice and lengthens the cut. The cutting edge of a saw tooth, however, is bounded by a more obtuse angle than that of a chisel, and as a cutting tool is inferior. Thus, if one of the three teeth shown by Fig. 60 is applied to a saw kerf in the position it would occupy as part of a complete saw, it will appear as represented by Fig. 61, its motion being in the direction of the arrow.

Fig. 63



It is defective as a cutting tool, because of the position of the line *ab*, the advancing face of the tooth.

This defect is more clearly illustrated by Fig. 62; this shows how a chisel would look if its edge were made to cut in the same manner as that of a saw tooth. But the fact is that a great discrepancy exists between the form of the saw tooth and that of the chisel, for it has been demonstrated that a chisel, to give good results, must

be at least as acute as is indicated by the dotted line a ; and it would seem that the former might be improved by bringing it more nearly to the outline of the latter. Suppose this be attempted, and that the face of the tooth indicated by the line cb , Fig. 60, be changed to cb' . Such a change must result either in removing material from the tooth, and thereby weakening it, or in changing the line cd to a position cd' . In other words, if the tooth is not weakened, the space between it and the next will be reduced. Again, if to make the advancing face still more acute, the line cb'' is accepted, and the tooth is not made smaller (that is, weakened), there will be no space between it and the next tooth. Having no spaces, there can be no teeth, and consequently the attempted change is impossible. It will thus be seen that the angle of the advancing face of the ripping-saw tooth cannot, unless it is weakened, be much more acute than is shown by Fig. 60 and Fig. 61.

The form of the tooth may be wholly changed, however, to the outline shown by Fig. 63, and some advantage may thus be gained in respect of the cutting angle; but such a tooth, while suitable for machine-saws of considerable size, is too complicated for small saws.

Nothing remains, then, as a possible means of improving the cutting edge of the saw tooth, except a modification of the angle bcd , Fig. 60. If it could be shown that there is an excess of strength in the tooth, above what is needed to perform its work, the angle might be changed to $b'cd$, or even to $b''cd$, and the value of the tooth as a cutting tool be increased. Moreover, it does not at first seem unreasonable to attempt such a change, for it is evident that the cutting wedge of the chisel (which we have regarded as the typical cutting tool), while much more acute than the angle bcd , is yet strong enough to be entirely satisfactory.

A more careful comparison of the saw and chisel, however,

discloses the following facts: first, a saw tooth must be softer than a chisel in order that it may be set and filed, and being softer, is therefore weaker in its substance; secondly, the width of the saw tooth is less than half the width of the narrowest chisel made, and, in this respect also, it is at a disadvantage; and, thirdly, in using a chisel the operator's attention is given entirely to its one cutting edge, and if at any time it is likely to receive too much strain, it is at once relieved; while each saw tooth, on the contrary, forms but a small part of a tool that receives little attention and much vigorous handling while it is being driven through straight grain, crooked grain, or hard knots, as the case may be. From a consideration of these points, it seems clear that the cutting-angle of a saw tooth must be less acute than that of a chisel. But the degree of acuteness can be determined only by use. Fig. 60 shows the form which years of experience have proved the most practicable for general work, and while some benchworkers do file their saws "under," producing a tooth similar to $dc'b'$, as many more go to the other extreme and use a tooth similar to dcf . The typical form given is easily kept in order, and, when in that condition, will cut freely and well.

55. The Teeth of Cross-cutting-Saws. — If a ripping-saw is used directly across the grain, the fibers of the material will

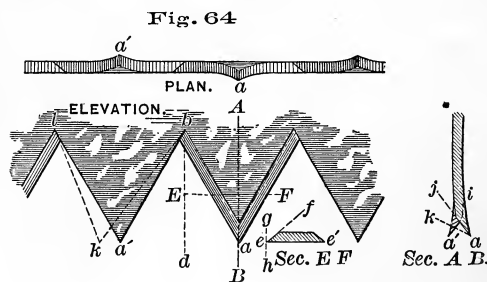

be torn from each other without being properly cut; hence the necessity for a saw that will "cross-cut." Fig. 64 shows by its three views a representative form of tooth for this saw.

It will be seen by the figure that the tooth terminates in a trian-

gular point ; and also, that while the point a is formed on one side of the blade, the next, a' , is formed on the opposite side ; thus throughout its length, the points of any two adjacent teeth being on opposite sides of the blade. This arrangement makes the end view of the blade show two parallel lines of points, and between them a triangular depression, which, when exaggerated by the "set," will appear as shown by section AB , Fig. 64.

In action, the points a and a' , Fig. 65, score the work, and the friction between the teeth and the cut fibers breaks up the latter, and they are carried off by the saw.

Fig. 65

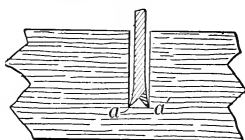

Assuming that it is a matter of convenience to have these teeth, as well as those of the ripping-saw, equal to the space between any two of them, there are three questions which may be considered concerning their proportions. First, what shall be the inclination of the advancing edge or "face" of the tooth, as represented by the line ab compared with the line bd , Fig. 64? Holly, in his little work on "The Art of Saw-Filing," shows the similarity of action between the advancing edge ab and the edge of a pocket knife when made to cut across the grain, and asserts that a knife with its cutting edge perpendicular to the surface upon which it acts (a position equivalent to bd) will make a rougher cut, and require more force to carry it forward at a given depth, than when it is inclined in a position similar to that of the line ab . The result obtained from such an experiment cannot be regarded as conclusive, because of the great difference in the character of the cutting edges compared. But, if it is found that the knife with its keen cutting edge behaves more satisfactorily at an inclination to the work, it seems reasonable to conclude that the rougher edge of a saw tooth will give the best results when much more inclined. A consideration of these points justifies the belief

that an angle of 60 degrees with the work, that is, with a line passing through the points a' and a , is none too great, and all practice goes to show that teeth so formed not only do very smooth work, but cut with ease and rapidity.

Secondly, what shall be the angle of the advancing face of the tooth, as represented by lines $e'e$ and ef , Sec. EF , Fig. 64? Since this angle forms the cutting wedge of the tooth, it should be as acute as is consistent with strength. Greater strength being required for action in hard wood than in soft, it follows that this angle should be varied with the material in which it is used. For general work it may correspond to the angle $e'ef$.

Thirdly, what shall be the acuteness of the point as indicated by the angle iaj , Sec. AB , Fig. 64? This, also, is determined by the character of the material to be cut. It should be more obtuse, as iak , for hard wood than for soft wood, not only because additional strength is required, but also because, if too acute, the scoring will be done so easily that the fibers between the scores will not break out, and the saw, being unable to pass down into new work, will slide along on the old.

Fig. 66

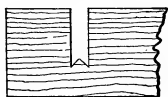
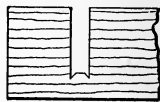

Fig. 67



Under such conditions, the bottom of the kerf will appear as shown by Fig. 66. A more obtuse angle will not penetrate the work so readily, but it will break up the fibers better, and thus leave the kerf in proper form as shown by Fig. 67. The softer woods break out more easily than the harder ones, and, consequently, a keener point may be used in working in them.

56. The Back-Saw is used only where accurate cuts are required. Its teeth, in form, are similar to those of the cross-

cutting-saw, except that the line of the advancing face is brought forward as indicated by *bkl*, Fig. 64, to increase their efficiency when used with the grain. They are, however, much finer, there being usually as many as sixteen to the inch. This saw cuts slowly as compared with a panel-saw, but may be used in very delicate work. It is used to cut in any direction relative to the grain of the wood. The bur left by the file after sharpening, forms a sufficient set.

Fig. 68

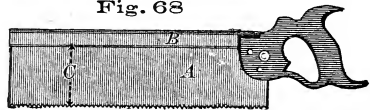

The blade *A*, Fig. 68, is in itself too thin to withstand the thrust necessary to drive it into the work, and is strengthened by an iron "back," *B*. This, being thicker than the blade, will not allow the saw to penetrate beyond a depth represented by the distance *C*. For this reason the blade is uniform in width instead of tapering.

57. **The Compass-Saw**, shown by Fig. 69, is intended for sawing in curved lines. Its blade is extremely thick, and the

Fig. 69

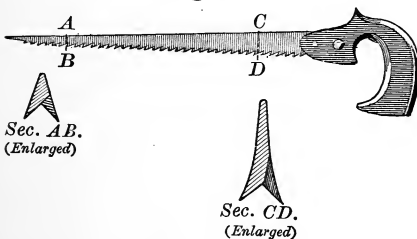

teeth are given an enormous amount of set. See sections *AB* and *CD*, Fig. 69. If the curve in which it is to be used is very small, only a short portion of the blade's length next the point can be used. With a curve

of longer radius, a greater length of blade may be brought into action.

Its teeth are of the form shown by Fig. 70, having the square face of the ripping-saw, and the point of the cross-cutting-saw.

Fig. 70



They are thus adapted for use in any direction relative to the grain of the wood.

APPLIANCES FOR SAW FILING AND SETTING.

58. A "Triangular Saw File"¹ is of the form shown by Fig. 71. A "slim" saw file is represented by Fig. 72; it is



REGULAR.

Fig. 73

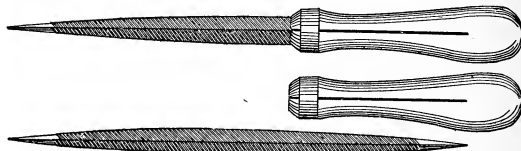

Fig. 74



Fig. 72



SLIM.

two inches longer than a "regular" saw file of the same cross-section. A "double ender" is shown by Fig. 73, and a cross-section of all saw files, on an enlarged scale, by Fig. 74.

59. **Saw Sets.** — Fig. 75 shows a simple form of set. The tooth to be bent is placed on the surface *A*, with

¹ Frequently called "three-square saw file."

the adjacent teeth in contact with *B, B*. Thus placed, the blade is allowed to rest on the screw *C*. A blow from a hammer on *D* bends or "sets" the tooth, and a spring returns *D* to the position shown.¹ The amount of set is regulated by the position of the screw *C*, and is greater, the lower *C* is fixed. If *C* is raised to coincide with the dotted line *AE*, the tooth will not be set. *B, B* can be adjusted to the depth on the tooth to which the set is to take effect.

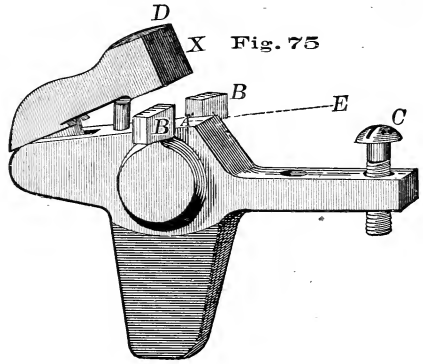

60. Swedge Sets for Ripping-Saws, illustrated by Fig. 76, are in general use on large saws and, occasionally, on small ones; generally speaking, they do not concern the bench-worker. The set is

Fig. 76

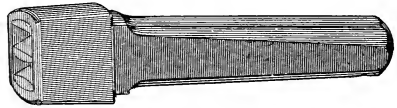
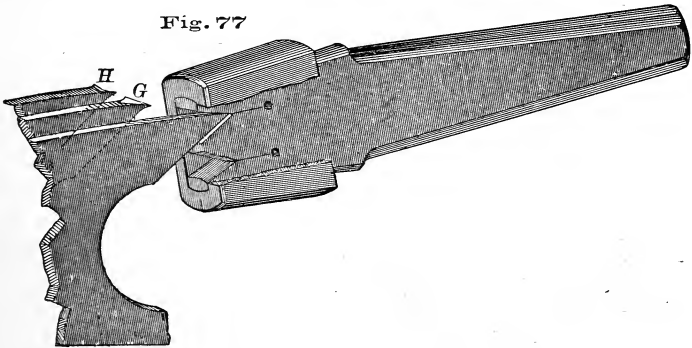

Fig. 77



¹ *D* is not well shown in the engraving. Since it must act on only one tooth at a time, the end *X* is wedge-shaped.

driven against the edge of the tooth, as shown by Fig. 77; by using one opening the center of the tooth is forced back, as at *H*; and by use of the other opening the points are spread, completing the work, as at *G*. A tooth thus set is more perfect in its action than when bent, since it cuts the full width of the kerf.

61. **Saw Clamps** are convenient for holding the saw during

Fig. 78

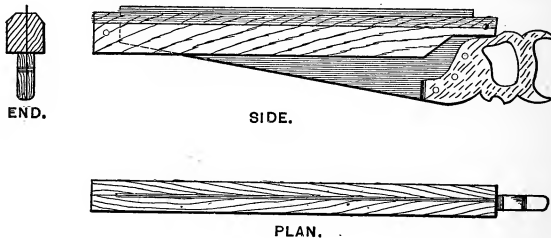

the filing process. Carpenters frequently make for themselves clamps similar to that represented by Fig. 78. It consists of two pieces of hard wood joined face to face by two screws (one near each end), by means of which the clamp may be

Fig. 79

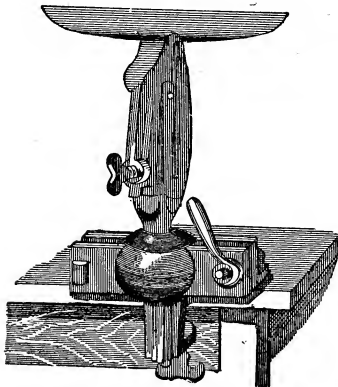

fastened rigidly to the blade of the saw. It may then be fastened in the vise or held on the knee while the saw is being filed. A much better device is the saw clamp shown by Fig. 79, which, while fastened to the bench, so holds the saw that it may be turned in almost any direction, thus enabling the workman to obtain a favorable light.

TO FILE AND SET A SAW.

62. Top-Jointing. — With the saw clamped teeth up, joint it by running a file along the tops of the teeth, as shown by Fig. 80. This is done to bring all the teeth to the same height, and also to maintain the form of the saw, which, along the line of the teeth, should be slightly convex. The jointing should leave a small facet on each tooth, which will be rectangular in a ripping-saw and triangular in a cross-cutting-saw.

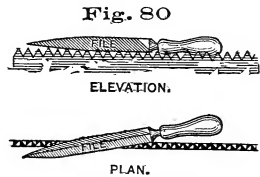

63. Setting. — Beginning at one end, bend outward every second tooth, then turn the saw and bend the remaining teeth toward the opposite side of the blade. In the case of the ripping-saw, if the swedge set is used, the setting should be done before jointing.

64. Filing. — It is of great importance that the saw be properly supported during the operation of filing. An unusual amount of noise shows that the blade is not properly clamped, or that the file is not being properly handled; it is also a sure indication that the filing is not going on as fast as it might, and that the file is being injured. If the file is new, let the pressure be very light. Carry it across the work with a slow, steady movement. Never take short, quick strokes, as but little will be done in this way, and the file will suffer beyond repair. In filing a ripping-saw, the movement should be exactly perpendicular to the plane of the blade, as indicated by plan, Fig. 81, and the outline of the teeth maintained by an even contact, as shown by the elevation in the same figure. But if the form of the teeth is to be changed, the file must be turned either in the direction indicated by the arrow, Fig. 81, or in the opposite direction.

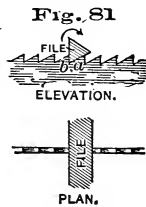

In filing a cross-cutting-saw, the angle between the file and

the blade must be varied in accordance with the following considerations: first, the outline of the teeth may be preserved or changed in the manner just described in connection with the ripping-saw; secondly, the angle of the advancing face (*e'ef*, Fig. 64) is determined by the inclination of the file

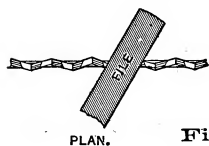
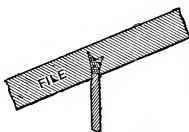

Fig. 82



SIDE ELEVATION.



END ELEVATION.

to the blade, as shown by the plan, Fig. 82; thirdly, the angle of the point (*iaj*, Fig. 64) is determined by the inclination of the file to the blade, as shown by the end elevation, Fig. 82. The form of the teeth having been decided

upon from principles already given, it may be produced without difficulty by attending to the foregoing directions.

In filing any of the teeth herein discussed, the file should always be in gentle contact with the face of one tooth, as *b*, Fig. 81, while most of the cutting is done on the back of the next one *a*, which, as usually considered, is the tooth that is being filed. This tooth should be one which, by its set, bends away from the operator. Beginning at one end of the blade, he files every second tooth until the opposite end is reached, when the blade is turned, and the remaining teeth filed from the other side.

No saw, even though the teeth are not bent, should be filed wholly from one side, for the file turns a slight edge, or bur; and, since this increases the set, it should be evenly distributed on both sides of the blade.

The filing on each tooth should continue until the facet produced by the jointing disappears. After this is accomplished, a single stroke will make the tooth receiving it lower than the others. To avoid this, it will be found best to leave

the teeth filed from the first side a little dull, for, in filing the intermediate teeth after the saw has been turned, the advancing faces of the others (the teeth first filed) are somewhat reduced. After every tooth has been passed over, if dull points are still to be seen, they may be sharpened from either side as their proportions may dictate. Regularity in the size and form of the teeth, and a similarity of appearance when viewed from either side of the blade, are the tests of good workmanship.

65. Side-Jointing.— Usually, when the filing is finished, the saw is ready for use, but it will cut more smoothly if it is jointed on the sides of the teeth. In Fig. 83, *B* is side-jointed, the surfaces produced agreeing with the dotted lines; *A* is not side-jointed.

Side-jointing may be accomplished by use of either a file or an oilstone. It is always necessary after a swedge set has been used.

Fig. 83

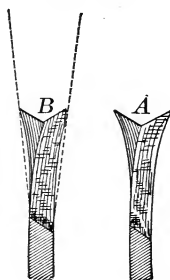

PLANES AND PLANE-LIKE TOOLS.

66. The plan and the section, Fig. 84, show a smooth-plane. The stock *a*, when of wood, is usually of beech. In it is an opening, or "throat," *b*, which receives the iron *c*; this is held in place by the wedge *d*. The lower part of the opening is called the mouth; and, as shown by the figure, the shaving passes into the mouth, and out through the throat. The bottom of the plane, which rests upon the work, is called its "face." The iron usually stands at an angle of 45 degrees with the face.

Fig. 84

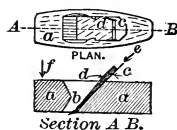

The bench-worker's set of planes comprises a smooth-plane, Fig. 85, which is about 8" in length; a jack-plane, Fig. 86, which is from 12" to 14" in length; a fore-plane, Fig. 87, from 22" to 26" in length; and a jointer, from 28" to 30" in length.

Similar purposes are served by the jointer and the fore-plane, the former being unnecessary except for large surfaces that are to be planed with accuracy.

Fig. 85

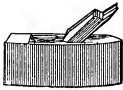

Fig. 86



Fig. 87



67. **The Length of the Plane-Stock** determines, in a measure, the straightness of the work. Thus, a smooth-plane, if used on

Fig. 88



an uneven surface, will, as shown by Fig. 88, rise over elevated portions and settle in hollows, taking its shaving without interruption, and producing no great change in the outline of the surface, while

Fig. 89

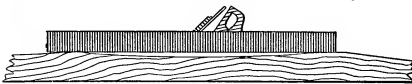

a fore-plane or jointer similarly applied will, as shown by Fig. 89, cut only on the higher parts, and by so doing, produce an even surface.

The stock of a smooth-plane is made short so that, by its use, a surface may be smoothed without incurring the necessity of straightening it.

The fore-plane will smooth as well as the smooth-plane, but not until it has first *straightened* the surface.

The jack-plane is used for cutting heavy shavings, and its length bears no relation to the character of the work expected of it, but is such as will enable the workman to grasp it easily and firmly.

68. **A "Plane-Iron"**¹ for a wooden plane is of iron overlaid in part with steel. Its cutting edge is maintained in precisely the same way as that of a chisel. See 47 and 48. The angle

¹ Known also as "plane-bit."

of the cutting wedge, however, for all except the jack-plane may be more acute.

69. The outline of the cutting edge, unlike that of the chisel, is never straight, being for the jack-plane slightly curved, as shown by Fig. 90, and for the smooth-plane and fore-plane (also for the jointer) of the form shown by Fig. 91. Being used for

Fig. 90



Fig. 91

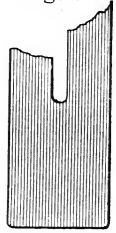

heavy work and frequently removing shavings as thick as one-sixteenth of an inch, the jack-plane, if its cutting edge were straight, would produce in the work at each stroke a rectangular channel from which the shaving must be torn as well as cut. Such a shaving would be likely to stick fast in the throat of the plane, or, under most favorable conditions, would require a large amount of force for its removal. A shaving removed by the iron represented by Fig. 90, however, is not rectangular in section, but thick

in the middle, tapering gradually to nothing at the edges. This form of iron is best adapted to the removal of a large amount of material at a stroke, but it leaves a succession of grooves upon the work which must be smoothed off by another plane.

70. The form of the cutting iron in the smooth-plane and the fore-plane, as shown by Fig. 91, is straight throughout the greater portion of its width, and slightly rounded at the corners. The objections urged against the use of such an iron as this in the jack-plane, do not apply to its use in the smooth-plane or the fore-plane, because the jack-plane, to fulfil its office, must remove a heavy shaving; the smooth-plane or the fore-plane, unless the surface upon which it acts is very much narrower than the width of the plane, is required to remove a shaving whose thickness rarely exceeds that of a sheet of paper. The

groove caused by the removal of so delicate a shaving, is sufficiently blended with the general surface of the work, by the rounded corners of the iron.

71. If a rough board is to be made smooth, or if a considerable amount of material is to be removed to bring a piece of wood to size, most of the surplus stock should be taken off by the jack-plane, after which the smooth-plane should be used to give the surface desired. If the finished surface is to be straight as well as smooth, the fore-plane should follow the jack-plane. It is never necessary to follow the jack-plane with both the smooth-plane and the fore-plane.

72. **The Cap.** — A supplementary iron, or “cap,” shown by

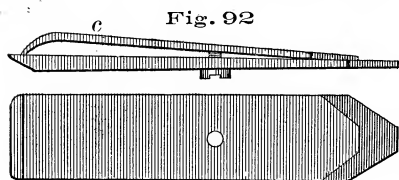

Fig. 92

c, Fig. 92, is fastened to most plane-irons. Its use is well illustrated by the two sections, Figs. 93 and 94. The single iron will do smooth work as long as the grain of the wood is favorable, as shown at *a*. When the

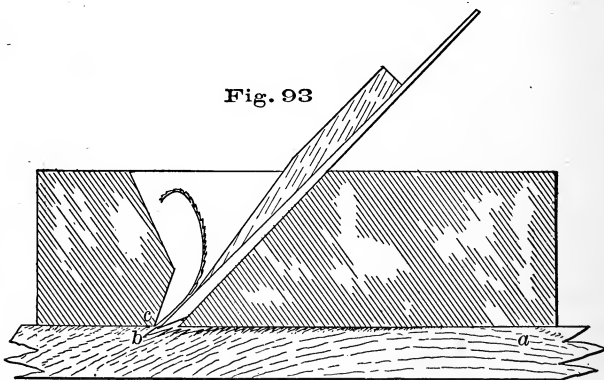
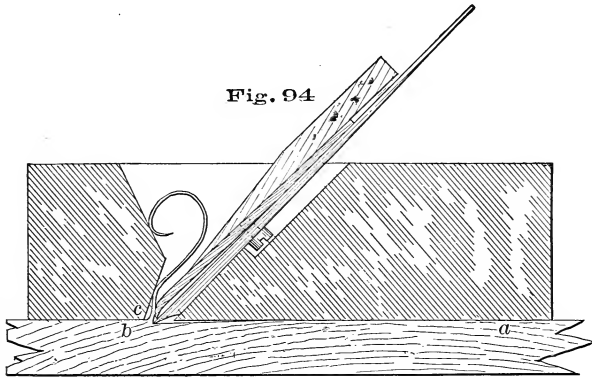

Fig. 93

grain becomes obstinate, as at *b*, the shaving, by running up on the iron, acquires a leverage which causes it to split in advance

of the cutting edge, below the reach of which it breaks, leaving a surface extremely rough. The office of the cap is to break the shaving as soon as possible after it is cut, Fig. 94, and thus prevent a gain of leverage on its part.



The distance at which the cap is set from the edge of the iron, must vary with the thickness of the shaving taken. For a smooth-plane or a fore-plane, a thirty-second of an inch is frequently not too close, while for a jack-plane an eighth of an inch may not be too great a distance.

A cutting iron and cap together are frequently spoken of as a "double iron."

73. Narrowness of Mouth in a plane is the chief element in the production of smooth surfaces. If, in Fig. 94, that portion of the stock in advance of the iron, marked *c*, were wanting, the shaving, having nothing to hold it down, would rarely be broken, notwithstanding the presence of the cap. A wide mouth would produce a similar effect. This being true, whatever other conditions there may be, the wider the mouth is, the less frequently the shaving will be broken and, in obstinate grain, the rougher will be the work.

74. **To Adjust the Iron.** — To set the iron deeper, so that a heavier cut may be taken, strike it a light blow, as indicated by the arrow *e*, Fig. 84. If a lighter cut is required, strike the stock as indicated by the arrow *f*. When the iron is in the right position, a light blow will tighten the wedge. To remove the iron and wedge, turn the plane over so that the face is uppermost, grasp the iron and wedge with the right hand, hold the back end of the plane between the thumb and finger of the left, and strike the stock at *f* upon the surface of the bench. A single blow is usually sufficient.

Never strike the plane while it is resting on the bench or any support that is firm. It should be held in the hand clear of everything; but, if this is not convenient, one end may rest on the knee.

To set the iron in a wooden plane, hold the stock in such a way that, while the face rests on the hand, the end of the forefinger may extend across the mouth. Put the iron in place, allowing its cutting edge to rest on the forefinger, which should keep it from projecting. Insert the wedge, push it down with the thumb, and by a light blow with the hammer drive the iron down until its projection beyond the level of the face is equal to the thickness of the shaving that the plane is to take; a single tap on the wedge will then tighten the iron in place. The distance that the iron projects, can easily be determined by sighting along the face of the plane.

The wedge must not be driven too hard, for a plane may be so distorted by a hard-driven wedge as to make it incapable of doing good work. The iron will be held in place even when the wedge is so loose that it may be drawn out with the fingers.

Notwithstanding the fact that wooden plane-stocks are made from material little affected by atmospheric influences, they will warp enough, especially when nearly new, to bring the face considerably out of a true plane. When, from this cause, the plane fails to do good work, it must be jointed.

75. **To Joint a Plane**, fasten it in a vise with the face up and the front end to the right. The iron should be in place, the cutting edge well back within the mouth, and the wedge driven as for work. It is now necessary to determine whether the plane to be jointed is twisted or not (97). Apply two parallel strips, or "winding-sticks," (the longer legs of two framing-squares will answer), one across each end of the plane, as indicated by Fig. 95. After making sure that they are parallel, sight across one to the other. As the eye is lowered, if the one farther away is lost sight of all at the same time, the plane is "out of wind," and needs only to be straightened; but, if one end of the straight-edge that is farther from the eye, disappears before its other end, as in the elevation, Fig. 95, it is evident that the two corners *a* and *b*, diagonally opposite, are high, and more must be taken from them than from the other corners. With this understanding, the fore-plane or the jointer may be applied until the plane is jointed, that is, until the face is a true plane.

During the planing process, frequent tests must be made with the parallel strips, to make sure that the high corners are being brought down properly. In the early stages of the work, the try-square may be used occasionally to keep the face as nearly as may be at right angles to one side, and the straightness of the face may be determined either by sighting or by use of the framing-square as a straight-edge. A true face having been produced, the sharp angles between it and the two sides should be changed to slight chamfers, inasmuch as the sharp edges, if not removed, are likely to splinter off.

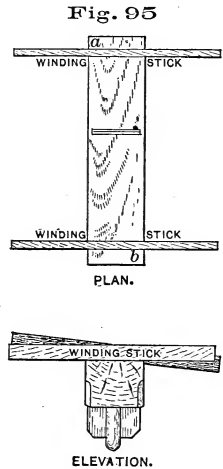

A few drops of lubricating oil rubbed on the newly-planed surface, will prevent wear and keep shavings from sticking.

Wooden bench planes have had their day, and are going out of use.

76. Iron Bench Planes

possess the general characteristics of the wooden ones, but are superior to them in several respects. They are always perfectly true and, therefore, never require jointing. The cutting "iron," which, in this case, is not of iron at all, but of steel, is much thinner than that in wooden planes, and is, therefore, more readily sharpened. Its greater thinness is made possible by the thorough manner in which it is supported. It may be set and accurately adjusted in a very short time.

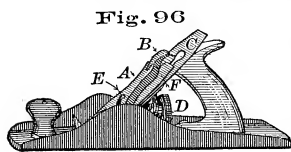

The arrangement of parts in Bailey's iron planes may be understood by reference to Fig. 96, which represents a jack-plane. The "wedge" *A* is of iron of the form shown; it admits the screw *E* through an enlargement of a short slot, and drops down, allowing *E* to take effect. By a movement of the clamp *B*, the wedge *A* is made to press upon the iron near its cutting edge, while the clamp presses against it at *F*. The screw *E* is never moved. The cutting iron is adjusted for depth of cut by the action of the thumb-screw *D*, which, when turned in one direction, moves the iron downward, and when its motion is reversed moves it upward.

Thus a single movement of *B* releases the wedge and iron, and a reverse movement secures them again, while *D* furnishes a ready and positive means for adjusting the cutting edge with a degree of delicacy which it is impossible to attain in wooden planes. These planes, all having the same adjustments, are made in every size.

77. **Planes of Wood and Iron Combined** may be had, made up of the Bailey movements mounted in a suitable frame, to which a wooden face is fastened. Fig. 97 shows a Stanley combination smooth-plane.

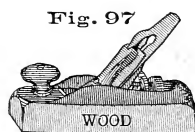

78. **A Circular-Plane** has a thin steel face, straight when free, but capable of having its ends thrust down or drawn up, thus making the face concave or convex, and adapting it to work on an outside or an inside curve. Fig. 98 shows a Bailey's adjustable circular-plane.

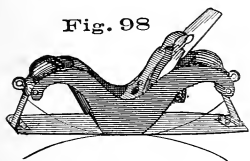

79. **Block-Planes** are small, and are intended for use chiefly on end grain. They generally have a single inverted iron, which turns the shaving on the bevel instead of on the face of the iron. They have many different forms, from among which Fig. 99 has been selected as a type. In this plane the throat may be made narrow or wide as is desired; the adjustment is controlled by the screw *A*.

Fig. 99

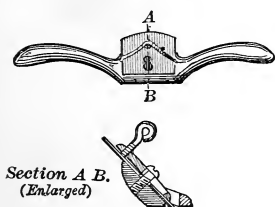

Fig. 100

Section A B.
(Enlarged)

80. **Spokeshaves** have the action of planes, but are not usually classified with them. A simple form is shown by Fig. 100. By the cross-section it will be seen that it has almost no guiding surface corresponding to the face of a plane. This feature adapts it to work of irregular outline.

81. **Rabbeting-Planes** have narrow stocks. The cutting edge is set in the face of the plane obliquely, and the iron is wide enough to extend beyond the sides of the stock, as shown

by Fig. 101. Rabbeting-planes are designed for use in interior angles. The oblique position of the iron produces a shearing cut which promotes smoothness in action.

Fig. 101

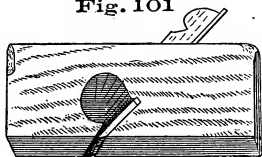

The shaving of the rabbeting-plane instead of passing through the stock is turned in such a way as to be discharged from one side; an arrangement common to matching-planes, beading-planes, molding-planes, and plows (82, 83, 84, and 85).

82. Matching-Planes are used to form a tongue and a groove, as shown respectively by *a* and *b*, Fig. 102.

Wooden matching-planes, Fig. 102, are sold in pairs, one plane being fitted with a single cutting edge, to form the groove, the other with a double cutting edge, to form the tongue. Both are guided by the "fence" *C*, which moves in contact with the working face of the piece operated upon. The groove and the tongue should both be carried to as great a depth as the plane will cut.

Fig. 102

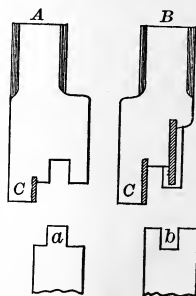

An iron matching-plane, designed to serve the purpose of the two wooden ones, is now in general use. Its fence is pivoted to the face in such a way that it can be turned end for end; in one position two cutters are exposed and the plane is adjusted to form the tongue; when its position is reversed, the fence covers one of the cutting edges, and puts the plane in shape for making the groove.

Fig. 103

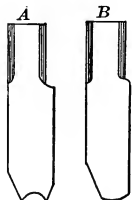

The size of matching-planes is indicated by the thickness of the material they are intended to match.

83. Hollow and Round are terms applied to such planes as are shown by *A* and *B*, Fig. 103. They are used, as their forms suggest, in producing hollows and in rounding projecting edges. Their size is indicated by a number, or by the width of the cutting edge.

84. Beading-Planes are used in forming beads (220), and they may be single or double, that is, form one or two beads at a time. For beading on the edge of work, they are provided with a fence, *A*, Fig. 104. For use away from the edge, they are made to form three

Fig. 104

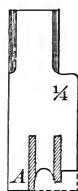
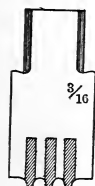

Fig. 105



or more beads at the same time, and have no guide, in which case they are known as reeding-planes, Fig. 105. The first three beads are made with the plane guided by a straight-edge temporarily fastened to the surface of the work; the remainder are formed by using those already made as a guide, the plane being moved into new work at the rate of only one bead at a time. Other

beading-planes, more complicated than those described, are constructed on much the same principle as a plow. The size of a beading-plane is indicated by the width of the bead it will form.

85. Plows are used in making rectangular slots or "plows" of any width, depth, and distance from the working-edge of the material. The width of the cut is ordinarily determined by the width of the iron used. A set of irons is supplied with the tool, which is shown by Fig. 106. A plow wider than the widest iron can, of course, be made by going over the work a second time. The depth of the cut is regulated by a little shoe (not shown), which is raised or lowered by the screw *A*. When this is adjusted, the tool can be used until

Fig. 106

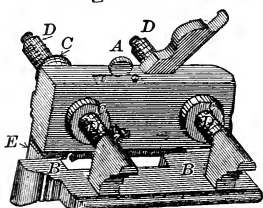

the lower surface of the shoe comes in contact with the face of the work, after which the cutting ceases. Care should be taken that the full depth is reached at all points along the length of the work. The distance between the groove and the working-edge is regulated by the fence *B*, which is adjusted by nuts *C* acting on the screws *D*. When ready for use, the fence should be parallel to the narrow iron face-piece *E*.

86. Combination Planes which may be used in place of the plow, beading-plane, rabbeting-plane, etc., are found on the market, and many of them are serviceable tools.

87. Scrapers.—Hand-scrapers are made of saw-plate—

Fig. 107

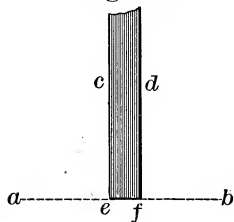

material of about the thickness of a panel-saw blade, and having the same degree of hardness. They are usually rectangular, and about 4" × 5", but may be of almost any size and shape. The cutting edge is most easily formed by the production of a surface at right angles to the sides, as indicated by *ab*, Fig. 107, thus giving

two cutting angles, *cef* and *dfe*. When a more acute cutting edge is desired, the form shown by Fig. 108 may be adopted; but, as a rule, there is little gained by the keener cutting edge, and double the labor is required to keep it sharp. Scrapers are sharpened by filing or grinding. If smooth work is to be done, the roughness of the edge may be removed on an oilstone, but the rougher edge will cut faster and, generally, will be more satisfactory.

Fig. 108

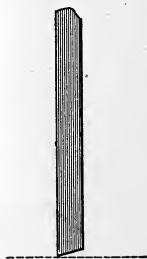

Fig. 109

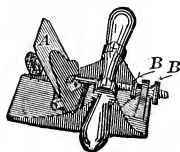

Fig. 109 shows a scraper mounted somewhat like a plane. The scraper blade *A*, by means of the two nuts *B, B*, may be changed from a position inclined to the face, as shown, to one perpendicular to the face.

BORING TOOLS.

88. **Augers.** — Fig. 110 shows a double-twist spur auger, a form generally used by carpenters. They are made in sizes varying from $\frac{1}{2}$ " to 4" (in diameter), but are not much used below 1". The spur *A*, Fig. 111, is in the form of a tapered screw, which, besides centering the auger in its motion, draws or "feeds" it into the work. The two nibs *B*, *B* score the work, and the lips *C*, *C* cut and remove the shavings, which are carried

Fig. 110

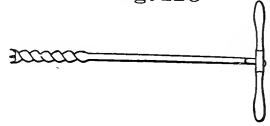
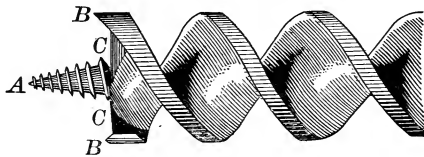

Fig. 111



to the surface by the screw-like action of the body of the tool.

Fig. 112 shows part of a single-twist auger which, as will be seen, has but a single nib *B*, and a single cutting lip *C*. The cuttings are thrown into the center of the hole, and de-

Fig. 112



livered easily by this auger, and, in this respect, it is superior to the double-twist, which crowds the cuttings to the outside of the hole, where they are likely to become jammed between the tool and the work. This characteristic of the single-twist auger particularly adapts it to the boring of deep holes. "Ship augers" are of this kind, and have handles like the one shown by Fig. 113. This form of handle

Fig. 113

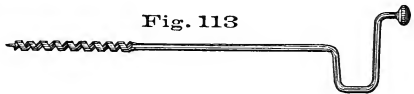

has the advantage of allowing the use of both hands, without the interruption experienced in using the one illustrated by Fig. 110.

Augers are seldom required by the bench-worker, but are presented here because of their relation to other boring tools.

89. Auger-Bits. — The auger-bit most in use is shown by Fig. 114. It is sold in sets of thirteen bits each, varying in



Fig. 114

size by sixteenths, from $\frac{1}{4}$ " to 1". Each bit is marked by a small figure on the shank, which indicates its

size in the scale of sixteenths. Thus the figure 9 is to be interpreted as $\frac{9}{16}$ ".

90. Augers and auger-bits are sharpened by filing. The scoring nib *B*, Figs. 111 and 112, which is usually the first part to become dull, should be filed wholly from the inside. If filed on the outside, the diameter of the cut it makes will be smaller than that of the body of the bit. The cutting lip *C* should be sharpened from the lower side, the file being inclined to preserve the original angle. With the spur in good order, whenever the tool refuses to "feed," it is clear that the bit needs sharpening somewhere.

91. Center-Bits are convenient for boring holes of large diameter in delicate material, such as would be likely to split under the action of an auger-bit. By reference to Fig. 115, it

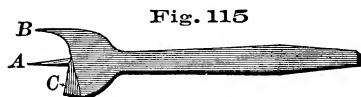

Fig. 115

will be seen that the spur *A*, which centers the bit in the work, is triangular in section.

This form allows the bit to feed rapidly, or very slowly, in accordance with the degree of pressure applied to it. The point, or "nib," *B* cuts the fibers about the proposed hole, and the cutting lip *C* removes the material. The center-bit does not work well in end grain. When dull it may easily be sharpened by whetting.

92. **Expansive Bits** are so constructed as to be adjustable for holes of any size, within certain limits. There are several forms in use, one of which is shown by Fig. 116.

This, without the movable cutter *C*, will bore a hole $\frac{3}{4}$ " in diameter, the screw *A* centering

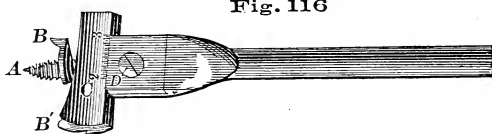

Fig. 116

and feeding it into the work, *B* scoring, and a cutting lip in advance of *B* (not shown) removing the shavings. When *C* is inserted as shown in the figure, in addition to the action just described, there is a supplementary action on the part of *C*, its nib, *B'*, scoring, and its cutting edge removing the chips. The cutter *C* is held in place by the screw *D*. By loosening *D*, *C* may be moved from or towards the center of the bit, or taken out altogether, and replaced by a cutter of different length. By using a short cutter in the place of *C*, a hole of any diameter from $\frac{3}{4}$ " to 2" may be bored, and with the cutter shown, any hole from 2" to 3" may be bored. The range of the bit, therefore, is from $\frac{3}{4}$ " to 3".

93. **Small Bits.** — Bits for boring holes less than $\frac{1}{4}$ " in diameter are of many forms, but by far the most satisfactory is the "quill" bit shown by Fig.

Fig. 117



117. It has no delicate parts; if carefully handled it will not split the material;

it enters the work rapidly, makes a round, smooth hole, and when dull can easily be sharpened by whetting or grinding. It will not, however, work with the grain. Quill bits as small as $\frac{1}{16}$ " in diameter are in common use.

Gimlet-bits are illustrated by Fig. 118, which represents one of the best forms. Most bits of this class are too weak to render the ser-

Fig. 118



vice expected of them, and soon become bent or broken. They are likely to split the work and are not easily sharpened.

94. Bit-Braces.—The well-made wooden brace, which for a long time ornamented the walls of the cabinet-maker's shop, has disappeared, and the lighter and more convenient iron brace is used in its stead. A simple form of iron brace is represented by Fig. 119. To insert a bit, grasp the sleeve *A* and, holding it firmly, turn the brace out by using the other hand on *B*. When the jaws, *C*, are opened sufficiently to admit the bit shank, put it in place, reverse the motion of the hand on *B*, and the bit will be fastened.

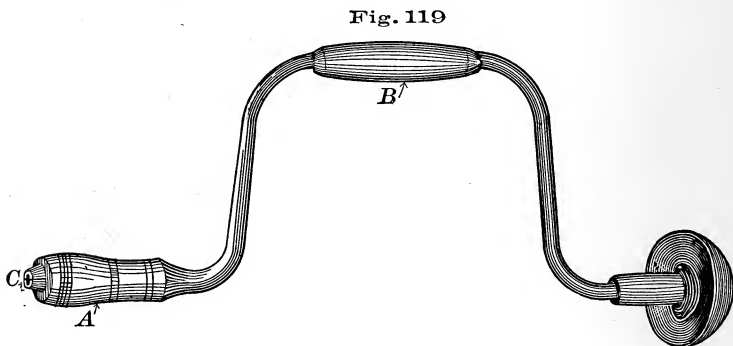

A *ratchet brace* is shown by Fig. 120. Its office is to turn the bit forward while the brace itself, instead of making a complete revolution, has only a forward and backward movement. As represented by the section *AB*, the frame *c* is fastened to the body of the brace of which it becomes a part, *d* is a spindle which terminates in the socket *e*, and *f* is a ratchet-wheel, which is fastened to *d*. On each side of the ratchet-wheel there is a pawl which, when free to move in response to the action of a spring, engages the notches in the ratchet-wheel *f*. With the pawls thus engaged, the brace may be used in precisely the same way as the one already described. But, by turning the ring *g*, one of the pawls is disengaged, and the other acting alone

will move the spindle *d* only when the brace is moving in one direction, the pawl simply slipping over the notches of the ratchet-wheel when the motion is reversed. In this way, a bit may be driven to any depth although each movement of the brace may be less than half of a complete turn. By a proper movement of the ring *g*, the motion of the bit may be reversed.

Fig. 120

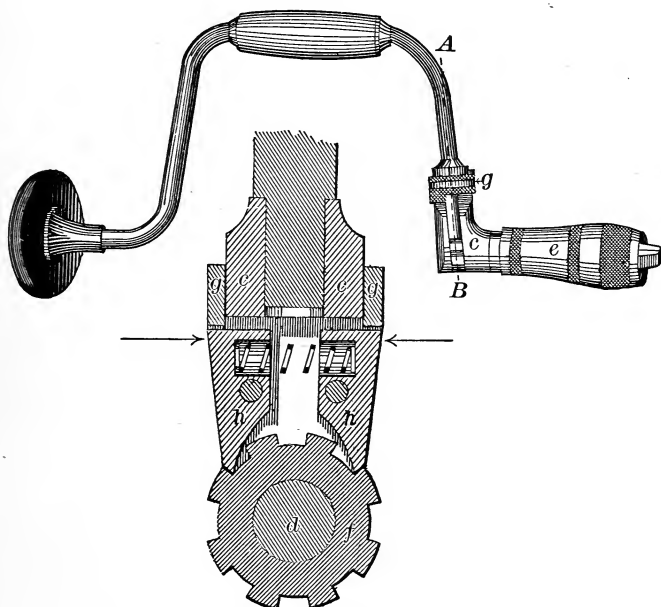

Section A B.
(Enlarged)

The ratchet-brace is useful in boring holes near walls, or in corners where it is impossible to turn a common brace.

The size of any brace is indicated by its "swing," that is, by the diameter of the circle described by *B*, Fig. 119. The better class are nickel-plated, and are thereby prevented from rusting.

95. A "Universal, Angular, Bit-Stock," such as is represented by Fig. 121, is, for many purposes, more useful than

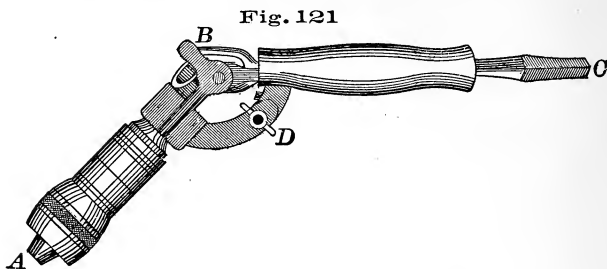

the ratchet-brace. The bit is inserted at *A*, and a common brace is applied at *C*. The mechanical arrangement of the parts is such, that, when the brace turns the spindle *C*, the part *A* which holds the bit is also turned, notwithstanding the inclination of one part to the other.¹ Compared with the ratchet-brace, this has the advantage of producing a continuous motion of the bit. By its use a hole may be bored in the corner as easily as in the middle of a room.

The angle of the joint may be changed from that shown to one of 180 degrees, by an adjustment at *D*.

96. **Automatic Boring Tool.** — A convenient substitute for a brad-awl is represented by Fig. 122. The drill, or bit, *A* is

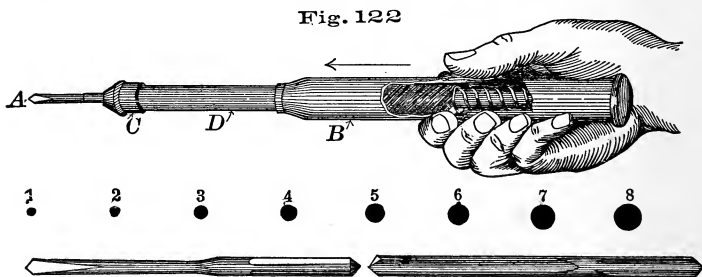

¹ Considered as a mechanical movement, this is known as Hooke's joint.

held in a suitable chuck *C*, at the end of the bar *D*, which runs in *B*. The drill is brought into contact with the work, and pressure in the direction of the arrow, slides *B* down upon *D*, and this movement causes *D* with the drill to revolve. The full extent of the movement having been reached, a relaxing of pressure leaves *D* free to return to its first position, as shown, the rotary motion of *A*, meanwhile, being reversed. These impulses can be imparted to the drill with great rapidity, and the work is quickly done. The dots below the figure, 122, indicate the full diameter of the different drills which are furnished with the tool.

MISCELLANEOUS TOOLS.

97. **Winding-Sticks**, or "parallel strips," are wooden strips of any convenient length, the edges of which are straight and parallel. When applied to a surface, they increase its breadth in effect, and by thus giving a better opportunity of comparison, show whether the surface is "in wind," or twisted. For an illustration of their use, see 75.

98. **Hand Screw-Drivers** are in form similar to that shown by Fig. 123. The part which is to engage the screw should have parallel sides, as shown by Fig. 124, and never be wedge-

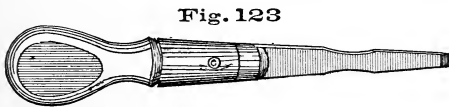

Fig. 123

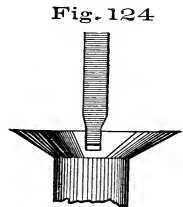

Fig. 124

shaped, Fig. 125. In the latter case, it will be seen that force applied in an attempt to turn a screw, will have a tendency toward lifting the screw-driver from its place.

A set of three or four screw-drivers, having blades varying in

size to suit different-sized screws, so that a fairly good fit may always be made, are indispensable to good work where screws are much used.

Fig. 125

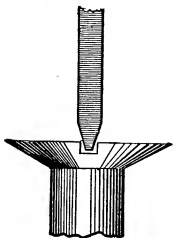

99. **Brace Screw-Drivers**, instead of having wooden handles, are provided with shanks for use in a brace. A good form is shown by Fig. 126. The brace gives a continuous motion, and the screw

Fig. 126

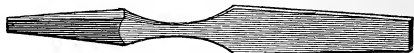

may be set much more rapidly by

its use than with the hand screw-driver. There are many cases, however, in which a brace is useless.

100. **Hammers.**—Fig. 127 shows a carpenter's hammer. The head *A* is wholly of steel. The face *B* is hardened so as not to be injured by repeated blows upon the nail, which is comparatively soft, but the idea prevailing among inexperienced workmen, that the hammer is indestructible, is a false one. When two bodies are brought together forcibly, as a hammer

Fig. 127

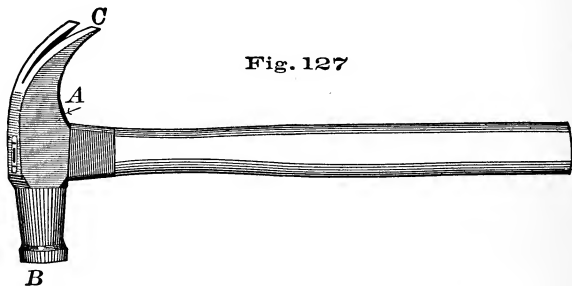

and a nail, the softer body yields, and a change takes place in its form. If the nail were harder than the hammer, it would not be injured, but the hammer would show an impression of the nail head. Careless or ignorant workmen sometimes take an

old file for a punch or a nail-set, and use a hammer upon it. The file is harder than the hammer, and the result is that the face of the latter is badly scarred.

The claw *C* makes the hammer a very effective tool for withdrawing nails.

Hammers vary in size from seven to twenty ounces; the bench-worker usually employs one weighing from fourteen to sixteen ounces.

101. **The Hatchet** is a useful tool for bringing large pieces of material to size roughly, and in skillful hands it may be used with accuracy as well as effect. When it is compared with the hammer, it will be seen that a blade *C*, Fig. 128, takes

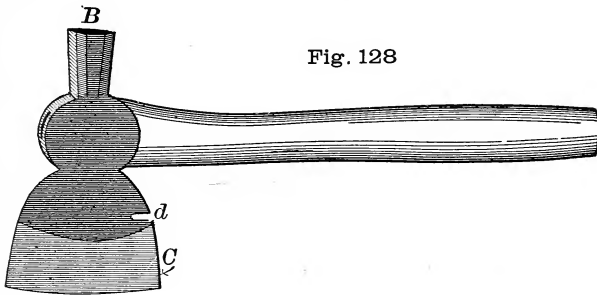

Fig. 128

the place of the claw *C*, Fig. 127. As an instrument for driving nails it is clumsy, and the opening *d*, for withdrawing nails, amounts to but little. In sharpening, the hatchet is ground on both sides of the blade, and whetted on an oilstone.

102. **Mallets.**—The difference in effect between a blow given by a hammer and one given by a mallet is so great that, although similar in many respects, the two tools are adapted to widely different uses. A blow from a hard, elastic hammer is sharp and decisive, and its force is absorbed almost as soon as it is received. Comparatively speaking, therefore, its effect must be local. If such a blow is received on a chisel handle, for example, a large part of its force is wasted in affecting the

handle, a part only being transmitted through the handle to the cutting edge, the only place where it can be of use. A blow from a soft, less elastic mallet, on the contrary, is more general in its effect. Much of the force remains for an instant stored in the mallet, by which it is given out somewhat gradually, allowing time for the impulse to pass beyond the point where it is received. The effect of two different explosive agents will serve as an illustration. As compared with nitro-glycerine, powder burns slowly, and, when put into a rifle barrel, gradually develops its force upon the bullet until, when the latter reaches the end of the barrel, it has gained velocity enough to carry it a mile or more. But if a charge of nitro-glycerine,

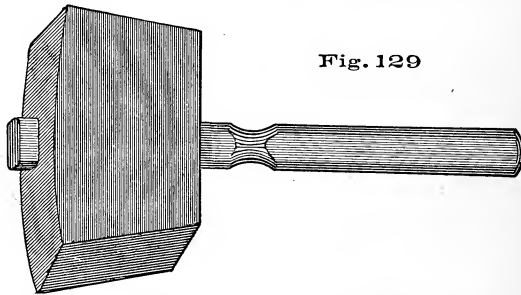

Fig. 129

having a total explosive force no greater than that of the powder, be substituted, the result will be very different. The rapidity with which nitro-glycerine burns — the suddenness of the impulse — is such that, before the bullet can respond to its influence, the breach of the barrel is destroyed.

The blow of a mallet on a chisel resembles the action of powder on a bullet. It is a *pushing* action, and, in this respect, is unlike that of the hammer. A chisel, therefore, will be driven deeper into the work by a blow from a mallet than by one of the same force from a hammer, while a chisel handle which has withstood blows from a mallet for years, may be shattered in a single hour by use under a hammer.

An excellent form of mallet is shown by Fig. 129.

103. Sand-Paper is neither a tool nor an appliance, strictly speaking, but, on account of its tool-like action, it should be mentioned with them. The "sand" used in making sand-paper is crushed quartz, and is very hard, angular, and sharp. It is graded as to degree of coarseness, by precipitation, and then glued to paper. The finest sand-paper is marked 00, from which the gradations run 0, $\frac{1}{2}$, 1, $1\frac{1}{2}$, 2, $2\frac{1}{2}$, and 3, which is the coarsest.

104. Miter-Boxes are useful in cutting the ends of light strips of wood at an angle of 45 degrees; they are frequently adapted to cutting at other angles. When of wood, like the one represented by Fig. 219, they are usually made by the workman himself.

A wooden miter-box is composed of three pieces—a bottom and two sides. It is necessary that the bottom piece be uniform in width and thickness, and have jointed edges, and it is well to prepare the other pieces in the same way. After the box is nailed, the sides should be square with the outside face of the bottom piece; this surface may now be used as a working-face. Lay off across the working-face two lines at a distance apart equal to the width of the face, thus forming with the outside edges of the box, a square. The diagonals of this square will represent the two oblique cuts, one marked *c*, and the one taken by the saw, Fig. 219. Project up the sides such lines from the points thus fixed, as will be useful in making the cuts; the sawing is then done with the back-saw. No special directions are required for laying off the cut *d*.

105. Iron Miter-Boxes are now in general use. The accuracy with which work may be done by the use of one will more than compensate any bench-worker for the money invested in it. Fig. 130 may be taken as a type; the work *A*

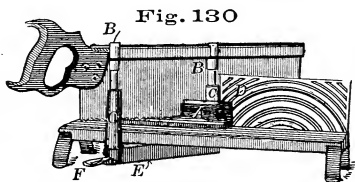

is supported by the frame as shown, while the proper position of the saw is maintained by the uprights *B*, which, in the sawing process, slide down into the standards *C*. The saw may be set at any angle with the back of the box *D*, by swinging the frame *E*, which supports the standards *C*; *E* is held in position by a suitable fastening operated by *F*.

106. Bench Clamps are useful in holding two or more pieces of material together temporarily. They are particularly valuable for keeping pieces that have been glued, in place until they are dry.

Wooden clamps, or hand-screws, are of the form shown by Fig. 131. The whole length of the jaws, *AB* and *A'B'*, may be made to bear evenly upon the work, or to bear harder at certain points, as *AA'* or *BB'*.

Iron clamps are illustrated by Fig. 132, but the mechanical arrangement differs in different makes. Such clamps are very

Fig. 131

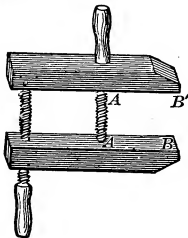
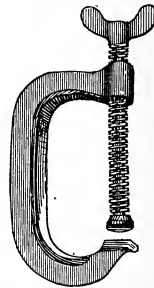

Fig. 132



useful in many kinds of work, but, all things considered, it is doubtful whether they are as serviceable to the bench-worker as the wooden ones just described.

107. Grindstones are selected with reference to their "grit." A coarse, soft-grit stone will remove material much more rapidly than one of finer grit, but the surface produced will be very rough compared with that produced by the other. Thus,

when it is necessary to remove material for the purpose of giving shape to a casting or forging, the coarse, soft-grit stone is better; but if a smooth cutting edge is required, one of fine grit should be used. For wood-working tools, a stone rather fine and soft is found best. The speed of a power grindstone must vary from 500 to 1000 circumferential feet a minute, depending upon its diameter, and the accuracy and steadiness with which it runs. It may not be well to run a 20" stone beyond the minimum limit, while one of 4' or 5' may give good results if run beyond the maximum. As a rule, a stone for tool-grinding is at its maximum speed when, if run faster, it would throw water from its face.

By circumferential speed is meant the speed of the circumference of the stone. This is found by multiplying the diameter of the stone, in feet, by 3.1416 (ratio of diameter to circumference), which will give the circumference of the stone, in feet, and this product by the number of revolutions per minute.¹

¹ *Example I.*—A 4' stone is run at 30 revolutions a minute; what is its circumferential speed?

The circumference of a 4' stone is

$$4' \times 3.1416 = 12.56'.$$

This would be the speed of the stone if it were to make but 1 revolution per minute; but, since it makes 30 revolutions, its speed is

$$12.56' \times 30 = 376.80' \text{ or } 377' \text{ (nearly).}$$

Example II.—It is desired that a 30" stone should have a circumferential speed of 280' per minute. How many revolutions should it make?

$$30'' = 2.5'.$$

The circumference of a stone 2.5' in diameter is

$$2.5' \times 3.1416 = 7.85'.$$

This would be the speed of the stone if it were to make 1 revolution per minute. But the circumferential speed is 280' per minute, and therefore the number of revolutions made must be

$$280' \div 7.85 = 36 \text{ (nearly).}$$

108. Water is used on a stone as a means of carrying off the heat resulting from friction between stone and tool ; it also washes away the particles of stone and steel that come from the grinding, and which, without the water, would fill the interstices between the cutting points of the stone, and make the surface so smooth as to be useless.

A grindstone, when not in use, should not stand in or over water. Water softens a stone, and one unequally exposed to moisture will be found softest in such places as are most exposed. When brought into use, the softer parts wear away more rapidly than the others, causing the stone to become "out of round." Water is best supplied from a tank, or from service pipes, so arranged that it may be shut off when the stone is not running, the drip-pan under the stone being at all times perfectly drained. After every precaution has been taken, the stone will in time become untrue and need attention.

109. To True a Grindstone.—When a stone becomes untrue, or the outline of the face, which should be slightly convex, becomes concave, it may be corrected by using a piece of soft iron as a turning tool, the stone being run dry. The action of the tool may be explained as follows: the soft iron allows small particles of the stone to imbed themselves in its surface, from which position they act against the revolving stone, and the cutting is done by these imbedded particles and not by the iron. The latter is worn in the process, however, and, as its cutting surface becomes enlarged, it should be turned to bring a new angle or face into action. This operation is easily performed by using a piece of gas pipe (about 1") for a turning tool.

110. Truing Devices are now generally attached to power grindstones. They are of several forms, of which that shown by Fig. 133 may be taken as an example. The base of this attachment is secured to the grindstone frame as near the stone as may be convenient. *A* is a hardened steel screw which revolves

freely on its bearings *B*. The frame in which *B* runs is pivoted at *C*, in such a way that by a movement of the hand-wheel *D*, *B* will move forward in the direction of the arrow. By adjusting the hand-wheel *D*, *A* is brought into contact with the face of the moving stone, and at once begins to revolve. The action of its thread would move it endwise, were it not prevented by its bearings. The effect of this angular advancement of the thread, which is not met by a corresponding lateral movement of the parts in contact, is a shearing cut across the face of the stone. When the screw becomes dull it may be softened and recut.

Fig. 133

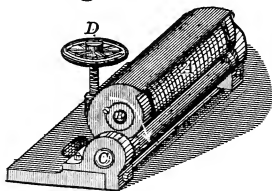

111. Oilstones. — The most useful of all oilstones are found near Hot Springs, Arkansas. They are divided into two classes, known to the trade as the *Arkansas stone* and the *Washita stone*. The former is of very fine grain, appearing much like white marble. It is used in sharpening the most delicate instruments, and produces an edge of remarkable keenness. The Washita stone is much coarser in grain, with a color sometimes almost white, but more frequently shaded by lines of a reddish cast. It cuts with rapidity, and with much greater delicacy than would be expected of so coarse a stone. Probably no better oilstone exists for sharpening wood-working and similar tools.

112. Oil is used on an oilstone for the same reason that water is used on a grindstone. To be serviceable, it should be as free as possible from all tendency to become thick or gummy. A good quality of sperm oil, or even lard oil, may be used; olive oil is frequently recommended.

113. Form of Oilstones. — It is evident that if oilstones could be made round, and mounted like grindstones, they could

be used more effectively than when only a small block is available. The reason they are not so mounted is that, in their native bed, the whetstone layers are traversed in every direction by veins of hard quartz, which, if allowed to enter into a finished stone, would destroy the cutting edge of any tool that might be applied to it. It is so uncommon to find large pieces of whetstone free from the quartz, that disks above 4" or 5" in diameter can be afforded only by those to whose work they are indispensable.

For bench purposes, Washita stones are about 1" \times 2" \times 7"; but no attempt is made to have them

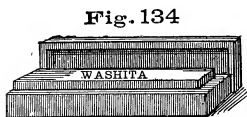

of any uniform size. Such a stone, when set into a block and provided with a cover to keep out the dust, is ready for use. See Fig. 134. Its surface

should be kept as nearly as possible straight, in the direction of its length, and should never be hollowed across its breadth. When out of shape it must be trued.

114. Slips of Washita stone whose cross-sections are round, square, triangular, etc., are supplied by the trade. A wedge-shaped slip



is represented by Fig. 135; it is a form extremely useful to the bench-worker.

115. **To True an Oilstone**, mix water with sharp sand until the mixture is thin enough to run. Apply a quantity of this to the surface of a flat board or plank, and, with the face that is to be trued in contact with the sand-covered board, move the stone about, frequently changing the direction of its motion. Under this treatment, the surface of the stone will be evened up rapidly. If the sand that is first applied becomes dull, it may be replaced by new.

Another, and usually a more convenient way, consists in substituting for the sand a sheet of sand-paper tacked over the edge of the board. Coarse paper may be used at first, and afterwards a finer grade selected for finishing the work.

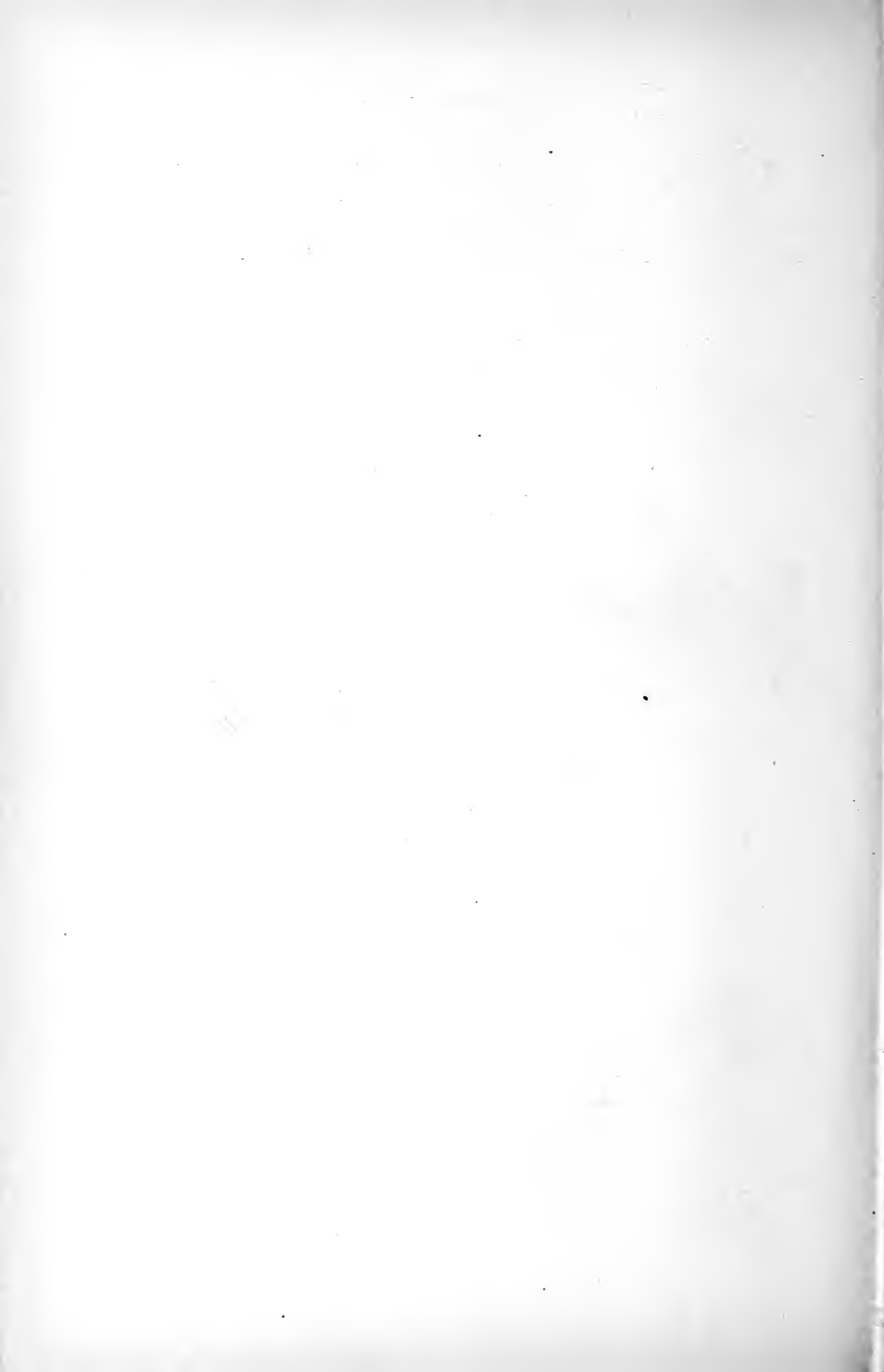

PART II.



BENCH WORK.¹

116. No work at the bench (9-13) is more important than that relating to the location and production of lines. Carelessness or want of skill in this will always be manifest in the finished work. To the beginner it may seem monotonous, and even hard, to stand at the bench several hours before turning a shaving; but he must understand that a scratch cannot be called a line, and that patience and accuracy are the chief requisites in skillful manipulation.

117. Location of Points (14-17).— All measurements must begin somewhere. The greater the number of points from which to begin, the more chances there are for mistakes. Thus in

¹ NOTE.—The material, or “stock,” needed for the exercises of the course should be straight-grained, free from knots, well-seasoned, and machine-dressed. A good quality of either white pine or yellow poplar is to be preferred. Good work cannot be done in poor material.

By easy steps the operations to be performed become more and more difficult. The student should not advance to a new exercise until the preceding one has been completed in a good, workman-like manner. A failure, unless the result of accident, should invariably be followed by another trial of the exercise. Otherwise, a careless habit is encouraged.

The course may appear brief, but experience has demonstrated its completeness as a preparation for constructive work in any of the lines to which it leads. After the fifteen exercises have been finished, if time remains, any ordinary piece of bench work may be undertaken.

measuring from *E* to *F*, Fig. 136, there is one chance for a mistake. If *G* is located by measuring from *F*, then in the loca-

Fig. 136

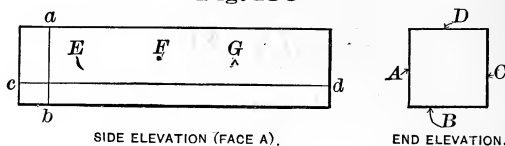

tion of *G* there are two chances for a mistake,—one in locating *F*, another in locating *G*; but if *G* is located by direct measurement from *E*, there is, as in the case of *F*, but one chance of error.

In locating a point by measuring from a point or line already fixed, it is necessary to make some kind of mark to indicate the distance. Haste in such work frequently results in a mark similar to that shown at *E*, Fig. 136, a “point” through which a line may be drawn with ease but with doubtful accuracy. A dot from a sharp pencil, as shown at *F*, Fig. 136, is much better; but if by reason of roughness of surface such a dot is too indistinct, two lines meeting each other at an angle may be used, *G*, Fig. 136, the point of juncture indicating the required location.

118. A Jointed Face is a surface that has been made a true plane. The necessities of practice so often require jointed faces at right angles to an adjoining face, that to many the term has come to mean not only a true plane, but such a surface at right angles to another, from which it is said to have been “jointed.”

119. A Working-Face is one selected as a guide for operations to be performed on an adjoining face. For accurate work the working-face must be jointed. At this face, all measurements have their beginning, and by it all lines are produced. If a piece of material is to receive lines on two opposite sides, as *A* and *C*, Fig. 136, either *B* or *D* may be used as a working-

face, but not both; if it is to receive lines on four faces, as *A*, *B*, *C*, and *D*, two of them, as *A* and *B*, for example, must be working-faces; if on six faces, three must be working-faces. For example, suppose lines are to be made on the surface *A*, Fig. 136, from *B* as a working-face; those running across the piece, as *ab*, will then be made perpendicular to *B*, and those running lengthwise, as *cd*, parallel to *B*. If, on the contrary, the working-face is disregarded, and some of the lines are made from *B* and some from *D*, their truth will depend not only on the truth of *B* and *D* as individual surfaces, but also upon their parallelism, and hence there is a double chance of error. Only one face, therefore, should be used from which to do the lining for a given surface. If lines are to be made on all four sides, as *A*, *B*, *C*, and *D*, and *A* and *B* are the working-faces, all lines on *A* and *C* can be made from *B*, and all lines on *B* and *D* can be made from *A*. It will be seen, therefore, that in making a piece a true square in section, it is necessary to use the beam of the square on only two faces.

EXERCISE NO. 1. — MEASURING AND LINING.

120. The stock required is $1\frac{3}{4}$ inches thick, 4 inches wide, and 4 feet long, or, as usually written, $1\frac{3}{4}'' \times 4'' \times 4'$. Fig. 137 shows the completed exercise.¹ To aid in following directions, it will be well to letter the four faces of the work *A*, *B*, *C*, and *D*, respectively, as indicated by Fig. 137 (End Elevation), and to mark two of them, as *A* and *B*, working-faces.

OPERATIONS TO BE PERFORMED ON FACE *A*, FROM *B* AS A WORKING-FACE, FIG. 137.

121. **Spacing with Pencil and Rule (18).**—By use of pencil and rule, lay off points *a*, 1'' apart along the whole

¹ Fig. 137 is broken in accordance with the principles given in 6.

length of the piece, the line of points being kept straight by preserving a uniform distance between them and the working-face *B*. This distance may be anything that is convenient, and will be sufficiently accurate if determined by the eye.

Fig. 137

Scale, 2"-1'

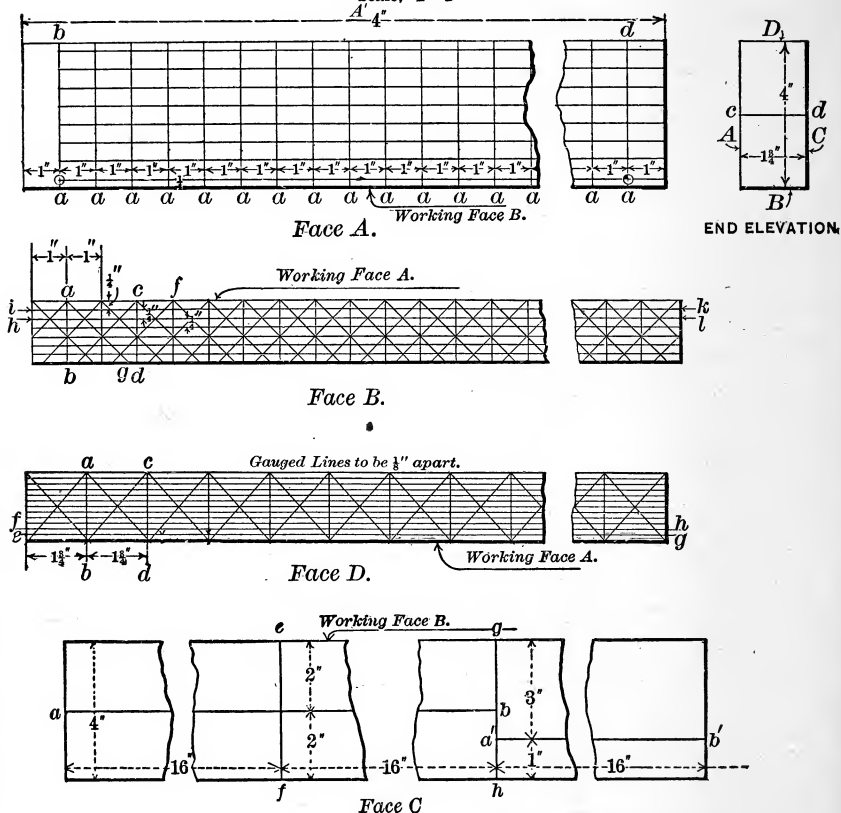

122. **Cross-lining with Pencil and Framing-Square (19-21).**—The points having been located, draw through each a line, as *ab* (Face A), using the framing-square and pencil.

While a line is being produced by the outside of the shorter leg of the square bc , Fig. 138, allow the longer leg ab to drop down so that its inside edge may be firmly pressed against the working-face, as indicated by the arrows d . When the progress

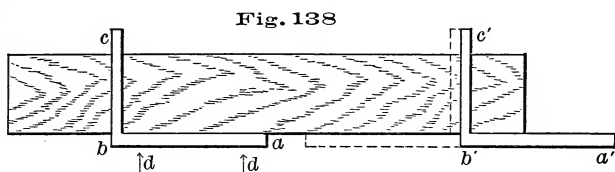

of the lining causes the leg ab to project beyond the work so much as to be imperfectly guided by the working-face, as shown at $a'b'$, Fig. 138, its position should be reversed as indicated by the dotted outline. This method must be observed in using any similar tool, as the try-square, bevel, etc.

123. Chalk-Lining (36).— Lay off points on lines ab and ad $\frac{1}{2}$ " apart, the first point in each case being $\frac{1}{4}$ " from the working-face. Through the points thus located, chalk-lines are to be made, as shown by face A , Fig. 137.

Insert the awl at the first point on the line ab , and drawing the cord tight with one hand, apply the chalk with the other,

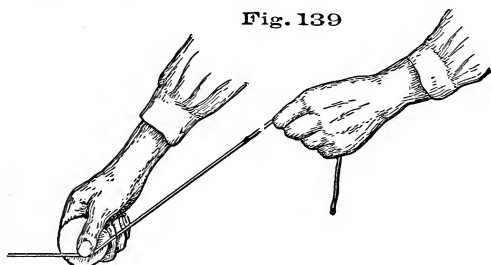

beginning at the awl. Care must be taken that the cake of chalk is not cut to pieces by the cord. A little practice will make it easy to hold the cord under the thumb in such a way as to form a small shoulder on the chalk, Fig. 139, which by

the friction of the cord will be gradually carried across the face of the cake; another is then formed to take its place. When the cord has been chalked, stretch it over the point on the line

Fig. 140

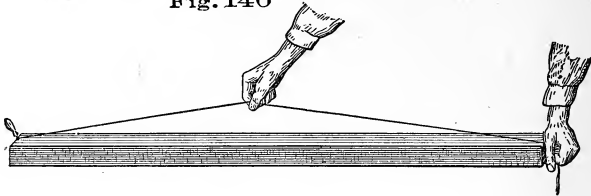

ad that corresponds to the point on the line *ab* at which the awl is inserted. Then raise the cord near the middle as shown by Fig. 140, and by suddenly releasing it, cause it to "snap" on the surface of the work. In snapping, the cord should be drawn up vertically, for if drawn at an inclination as shown by *a*, Fig. 141, a wide blurred line will be produced. Repeat this operation for each of the points, finishing face *A* as shown. Each line should be clear and well-defined. Try to make each one better than the preceding. Never snap more than once between the same points.

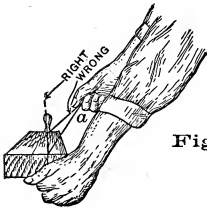

Fig. 141

OPERATIONS TO BE PERFORMED ON FACE *B*, FROM *A* AS A WORKING-FACE, FIG. 137.

124. **Lining with Pencil and Try-Square (22).**—Hold the beam of the square firmly against the working-face, and, using the outside edge of the blade as a guide, continue across face *B* the lines on the working-face which were made by use of the framing-square. If the work has been well done, the lines will be sharp, straight, and parallel, as shown by *ab*, *cd*, etc., Face *B*, Fig. 137.

125. Lining with Pencil and Bevel (23-25). — The bevel is to be set at an angle of 45 degrees, and the lines *ag*, *fg*, etc., drawn from the points made by the intersection of the lines already drawn and the working-face, Face *A*, Fig. 137. Hold the beam of the bevel firmly against the working-face, and use the outside of the blade to guide the pencil. Let the beam of the bevel bear firmly on the working-face.

126. "Gauging" Lines with Pencil and Rule. — These lines, as *ik*, *hl*, etc., are to be spaced $\frac{1}{4}$ " apart, as shown by Face *B*.

Grasp the rule at a proper distance from its end, in the left hand, and press the forefinger against the working-face, to which the rule is perpendicular, as shown by Fig. 142. With the right hand apply the pencil to the work, and at the same time press it against the end of the rule. In this way, the pencil against the rule, and the fingers of the left hand against the working-face, move along the length of the work, thus producing a line parallel to

the working-face. It is not necessary to lay off points, since the distance between the pencil and the edge can always be known by observing the graduations of the rule. In making a line, the pencil will be more easily kept in position if considerable force is used in pressing it against the rule; to prevent this force from displacing the rule, it must be met by a greater force acting in the opposite direction. See arrows *c* and *d*.

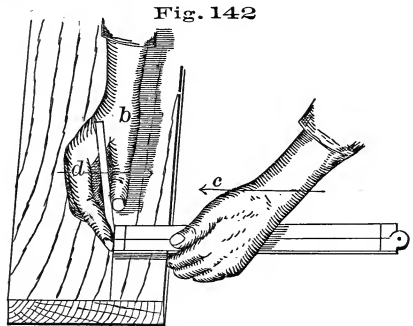

to the working-face. It is not necessary to lay off points, since the distance between the pencil and the edge can always be known by observing the graduations of the rule. In making a line, the pencil will be more easily kept in position if considerable force is used in pressing it against the rule; to prevent this force from displacing the rule, it must be met by a greater force acting in the opposite direction. See arrows *c* and *d*.

This is a rapid method of producing lines parallel to the working-face, where exactness is not demanded.

OPERATION TO BE PERFORMED ON FACE *D* FROM *A* AS A
WORKING-FACE, FIG. 137.

127. Spacing by Use of Scriber (37) and Rule. — Points and lines made with a pencil, while accurate enough for many purposes, are too inexact to define the proportions of different parts of a joint. Where good fitting of any kind is required, the pencil should not be used, but all points and lines be made with a scriber. The scriber should be sharp, and should make a clearly-defined cut, not a dent.

Using the rule, then, to determine the distances, substitute the scriber for the pencil, and, following the dimensions given (Face *D*, Fig. 137), lay off points along the length of the work through which the lines *ab*, *cd*, etc., are to be drawn.

128. Lining with Scriber and Try-Square. — Through the points already placed, scribe lines, as *ab*, *cd*, etc., with the try-square.

Care must be taken that the advancing edge of the scriber is not turned out from the square blade; in such a case, it is likely to "run out" from the square and give a crooked line. Neither should the scriber be turned in so much as to crowd the square from its position. After a little practice, lines can be scribed easily and rapidly.

129. Lining with Scriber and Bevel. — Set the bevel at an angle of 45 degrees and, using it as before, scribe lines from the ends of the try-square lines, as shown by *bc*, *ad*, etc.

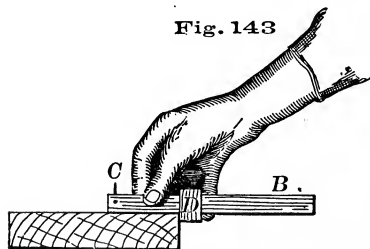

130. Gauge-Lining (32-35). The gauge provides the most ready means for the accurate production of lines parallel to a working-face. As shown in Fig. 143, the beam of the gauge *B* carries

a steel spur *C*, which does the marking. *B* also carries a head *D*, which is adjustable on the beam.

To use the gauge, adjust the head so that the distance between it and the spur *C* is equal to that between the working-face and the required line; then close the fingers over the head and extend the thumb on the beam towards the spur, as shown by Fig. 143. Holding the gauge in this manner, bring the head against the working-face, move the gauge along the work, and the line will be produced. To prevent the spur from sticking,

the first stroke should make a light line, which may be strengthened by a second, and even a third passing of the gauge.

The depth of the line in each case is regulated by turning the gauge as indicated by the relative position of *Y* and *X*, Fig. 144. It is obvious that no spacing is necessary when this tool is to be used.

By use of the gauge, lay off $\frac{1}{8}$ " apart the lines *fh*, *eg*, etc., Face *D*, Fig. 137.

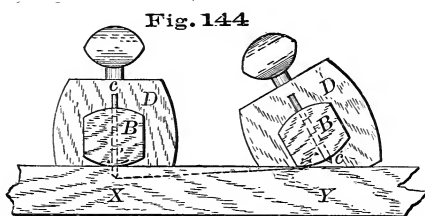

OPERATIONS TO BE PERFORMED ON FACE *C*, FROM *B* AS A WORKING-FACE, FIG. 137.

131. The lines on this face are to be used in Exercise No. 3. By applying the principles already developed (121, 122) locate the lines as shown by the drawing, Face *C*, Fig. 137. This work may be done with the pencil, the lines *ab* and *a'b'* being "gauged" by use of the rule (126). The line *cd*, End Elevation, may be made in the same way.

Fig. 145
Scale, 6"=1'

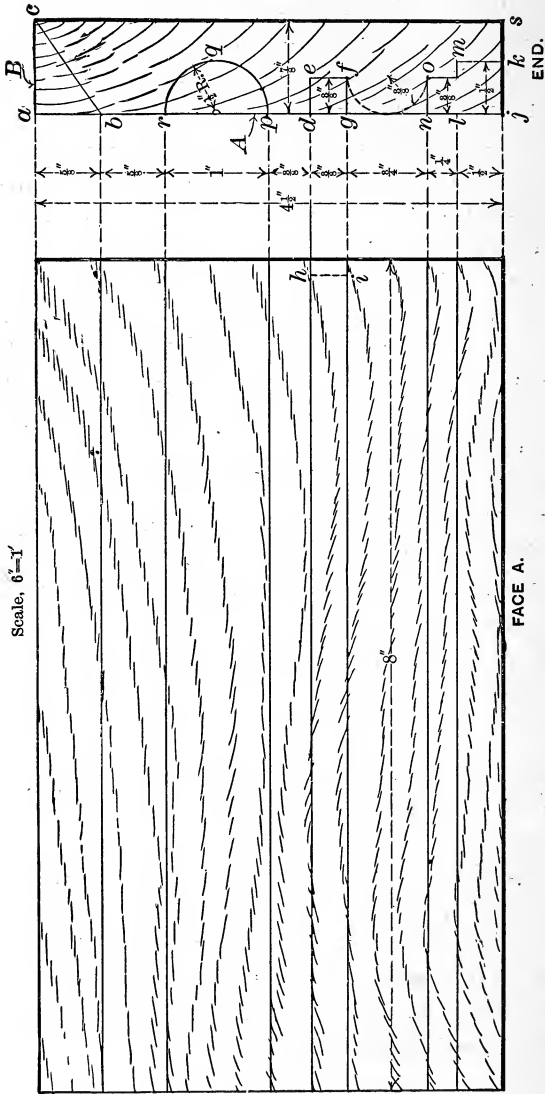

EXERCISE No. 2.

PRACTICE WITH CHISEL AND GOUGE (39, 40, and 42).

The stock required is $\frac{7}{8}'' \times 4\frac{1}{2}'' \times 8''$.

Fig. 145 shows the lines that are needed, all of which are produced as explained in the foregoing exercise, except the arcs of circles, which must be put in with the dividers (26); *A* and *B* are working-faces. An end elevation of the finished piece is represented by Fig. 146.

Fig. 146

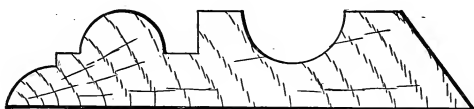

132. To remove the Portion *abc*, Fig. 145. — It is always best, in removing surplus wood with the chisel, to cut across the grain, as any attempt to carry the cutting edge along the grain is quite sure to result in a splitting action, the chisel following the grain of the wood, which splits ahead of it, and prevents the operator from controlling its course. In removing the portion *abc*, the work should be held in the vise with the working-face *A* toward the operator. A 1" chisel will be found of convenient size. Beginning at one end, make successive cuts with the chisel, as shown by Fig. 147. Each stroke of the chisel should cut almost to the full depth required (*i.e.* remove a shaving from the face of nearly the whole triangle *abc*), the thickness of the cutting varying with the character of the material and the

Fig. 147

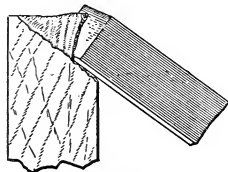

ELEVATION.

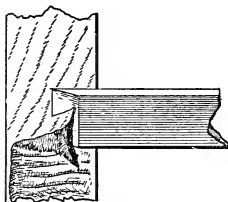

PLAN.

strength of the operator. It is best, however, to go slowly, for the chisel will not be properly guided if the workman's whole strength is required to push it through the wood. The surface thus produced will not be smooth, but it will be true to the line. To smooth it, a wide chisel should be used, as shown by Fig. 148, and a longitudinal movement imparted to it at the same time it is being pushed forward.

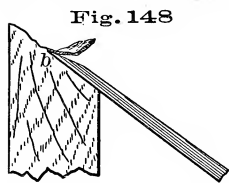

It will be noticed that both chisels are applied to the work in such a way as to turn the shaving from the bevel, and not from the flat face. This is done that the flat face may be available as a guiding surface, which, when kept in contact with the solid material back of the cut (see *b*, Fig. 148), will insure straightness in the forward movement of the cutting edge, and, consequently, accuracy of work.

133. To remove the Portion *defg*, Fig. 145. — With the

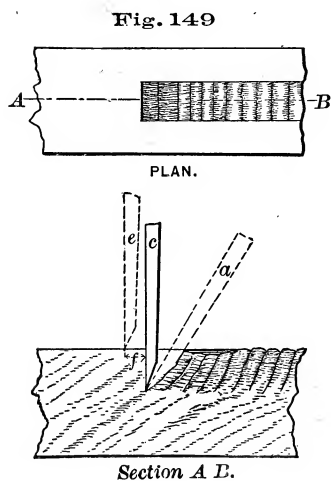

work flat on the bench, face *A* uppermost, place a $\frac{3}{8}$ " chisel so as to bring its cutting edge in the position occupied by the line *hi*, which is about $\frac{1}{8}$ " from the end of the work. With the mallet, drive the chisel vertically downward, as indicated by *c*, Fig. 149. When down to the depth of the required cut, the chisel should be pushed over to the position *a*, to make room for the next cut, after which it may be withdrawn and placed in position again at *e*. This operation is to be repeated until the whole length of the piece

has been passed over, making the work appear as indicated, in part, by Sec. *AB*, Fig. 149. The cuttings may then be removed. The sides of the opening will be even and fairly smooth. The distance the chisel is advanced (*f*) must depend on the material, and the depth to which it is driven; it should never be so great as to risk the breaking of the chisel when it is moved from position *c* to *a*.

To remove the portion jkon, Fig. 145.—Using the chisel as in the last exercise, remove the portion *jklm*, and afterwards the portion *lmon*.

134. To remove the Portion *pqr*, Fig. 145.—This is done with the gouge, which, unlike the chisel, may be used with the grain, as indicated by Fig. 150, the concave surface of the work allowing its individual fibers to give greater support to one another in resisting a splitting tendency. It will be seen that the bevel of the gouge is its only guiding surface. This being necessarily short, the tool is a difficult one to use. Light cuts should be taken, especially when the grain of the wood is not favorable.

Fig. 150

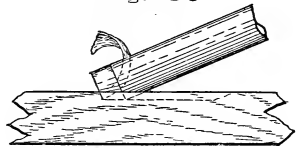

To finish Exercise No. 2.—By use of the chisel round the part between the lines *fg* and *no*, and also the part between the point *m* and the line *ks*, to agree with the finished form shown by Fig. 146, and smooth all chiseled surfaces not already finished.

EXERCISE No. 3. — SAWING (49-55).

The stock required is the finished piece from Exercise No. 1; it is to be cut as indicated by the lining on Face *C*, Fig. 137.

135. Handling the Saw.—The saw should be grasped firmly with the right hand, a better control of it being secured

by extending the forefinger along the side of the handle. In starting a cut, the side of the saw should be pressed against the thumb of the left hand, which then acts as a guide, as shown by Fig. 151. The saw must not be crowded against the work, but, on the contrary, to prevent the teeth from penetrating too deeply, its forward movement should be accompanied by a lifting action of the wrist. The saw should always be moved with a long stroke, bringing as many teeth into action as possible. A short, jerky movement is at no time necessary or desirable. It is good practice for the beginner to keep up the proper motion of the saw, while maintaining a very light contact between it and the work. Success in this exercise is to be measured by uniformity of contact throughout all points of the stroke.

There are two errors which are likely to be made in sawing: first, sawing off the line; and, secondly, sawing at a wrong angle.

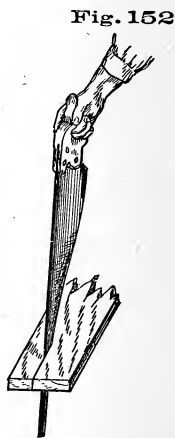
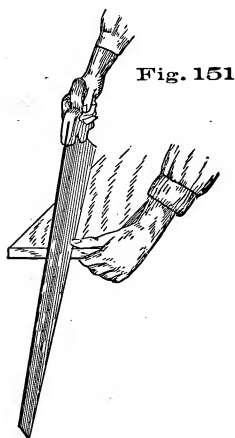

136. To guide the Saw.— If the saw tends to run off the line, the blade may be slightly twisted in the direction it ought to take, as shown by Fig. 152. It will immediately respond by a change in its course. The correction should be made as soon as the error is discovered.

137. To correct the Angle of the cut, the saw should be bent, as shown by Fig. 153, and at the same time moved vertically, as shown by Fig. 154, instead of in the usual direction, which is indicated by the dotted line *ab* in the same figure.

138. Rip-sawing on the line *ab* and *a'b'*, Face *C*, Fig. 137.— Start the saw on the lines *ab* and *cd* (the latter shown in End

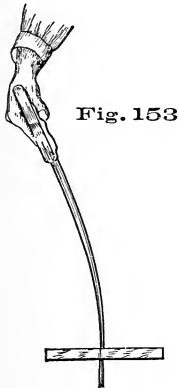

Fig. 153

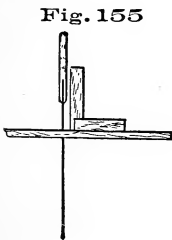

Fig. 155

Elevation). By following the first line the proper direction of the cut will be insured, and by keeping on the second the piece will be cut square with the working-face. The saw once started, the truth of the angle may be occasionally tested by the try-square applied as shown by Fig. 155. Attention given to this matter at first, will soon make the operator sufficiently skillful to judge the angle accurately enough for most work.

After cutting on the line *ab*, cut also on the line *a'b'*.

In sawing a piece from one end to the other in one cut, the saw, in coming out, should not be allowed to injure the trestle. This danger may be met by slanting the board so that it will be supported by one corner, thus leaving an open space between the trestle and the point where the cut will end, as shown by Fig. 156.

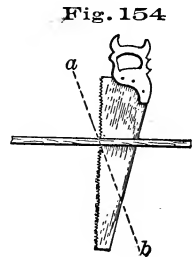

Fig. 154

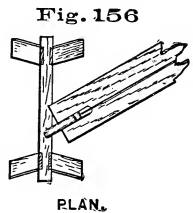
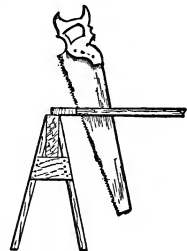

Fig. 156

PLAN.



ELEVATION.

139. Cross-cutting on the lines *ef* and *gh*, Face *C*, Fig. 137. — Observe the general directions that have already been given.

When the piece that is being cut is almost divided, there is danger that the uncut portion may break and splinter. This tendency must be guarded against by properly supporting the work, either by the hand or by a suitable arrangement of the trestles.

EXERCISE NO. 4.—PLANING (66–74).

The stock required is the pieces resulting from Exercise No. 3.

140. In grasping a plane, there is always shown a disposition to place the thumb of the left hand on the right side of the plane. This should not be done; for, as will be seen by Fig. 157, when the plane is drawn back, the arm, by contact with the body, becomes stiffened, and the motion of the plane restricted. The hand, therefore, should be so turned as to bring the thumb on the left side, as shown by Fig. 158. Held in this manner, the plane may be easily carried well forward and well back.

Fig. 157

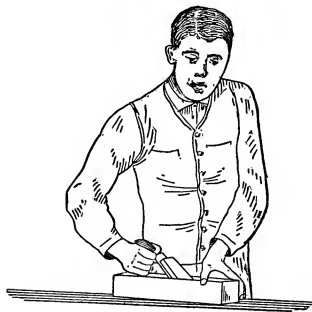

Fig. 158



When the surface of the work is large, begin to plane at its right-hand end. With a series of easy strokes pass across the face of the work, then step forward and take a second series of

strokes, and so on until the whole surface has been passed over. In the first series of strokes it is necessary to draw the plane off the work, as shown by Fig. 159. In doing this, sufficient pressure must be exerted in the direction of the arrow to overcome any tendency to tip, as indicated by the dotted outline; in the last series of strokes the wrist may, for the same reason, be rested easily on the back of the plane. To make the strokes between the ends properly, the plane should be lifted so that the shaving may be finished before the forward movement of the plane ceases. The plane need not be lifted bodily from the work. The natural, slightly-upward movement of the arm when stretched out, as shown by Fig. 160, will accomplish all that is necessary.

Fig. 159

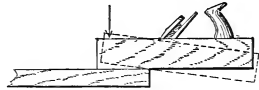
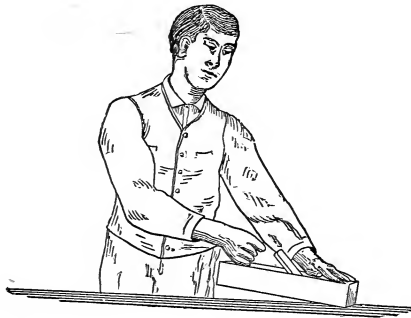

Fig. 160



If the plane is allowed full contact with the work on the backward stroke, a dulling effect on the cutting edge is produced, especially if the work is rough and gritty. Under such circumstances, it is better to raise the plane from the work entirely, or turn it on its edge, or draw it back in the position shown by Fig. 160. On small, clean surfaces, however, it is best to disregard this caution, since sharpening

takes less time than placing the plane before beginning each stroke.

In planing a narrow surface, for example, the edge of a board, difficulty in keeping the plane on the work may be overcome by grasping it in such a way that the fingers of the left hand, while pressing against the face of the plane, may maintain a light contact with the work, as shown by Fig. 161.

Fig. 161

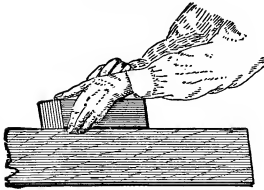

141. The mouth of a plane sometimes becomes clogged, and, as a result, the cutting ceases. This may be caused by a dull cutting edge, which scrapes off fibers which it cannot cut; or by the low set of the cap on the iron; or by a bad fit between cap and iron, which allows a shaving to find its way between them, thus forming an obstruction to the passage of other cuttings. In new planes, the stoppage may be due to narrowness of the mouth, which will not allow a thick shaving to pass. It should be remembered, however, that narrowness of mouth is an element in the production of smooth work, and for this reason the opening should be no wider than is absolutely necessary.

To preserve the face of the plane, apply occasionally a few drops of lubricating oil.

142. Jointing the sawed edge of the $1\frac{3}{4}'' \times 3'' \times 16''$ piece from Exercise No. 3, to finish at $1\frac{3}{4}'' \times 2\frac{3}{4}'' \times 16''$. Set the

Fig. 162

Scale, $1\frac{1}{2}''=1'$

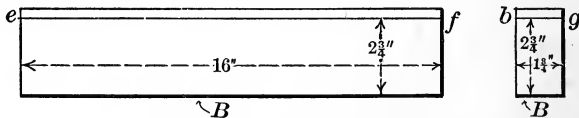

gauge at $2\frac{3}{4}''$ and from the working-face *B*, Fig. 162, gauge

lines all around the piece, as *ef* and *bg*. Fasten the piece in the vise with the sawed edge up; plane nearly to line with the jack-plane and finish with the fore-plane.

143. Planing to a Square each of the four $1\frac{3}{4}'' \times 2'' \times 16''$ pieces from Exercise No. 3, their finished size to be $1\frac{5}{8}'' \times 1\frac{5}{8}'' \times 16''$. Select a straight face, or, if none is exactly right, correct the best and mark it as a working-face. Let this be done on each of the four pieces. All old marks are to be planed off and new ones made as needed. Suppose Fig. 163 to represent an end of one of the pieces, and let *A* be its working-face. With the fore-plane, joint *B* from *A*, and mark *B* as a second working-face. Repeat this operation on each of the other pieces. Set the gauge at $1\frac{5}{8}''$ (the width to which each side is to finish), and from the working-face *A* gauge a line on *B*. From working-face *B* joint *C* to line, and perform this operation on each remaining piece. From *B* as a working-face with the gauge set as before, produce lines on *A* and *C*, and plane *D* to these lines. This done, the four pieces should be of the same size, and true squares in section.

Fig. 163

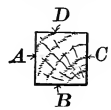

144. Whenever a series of similar operations is to be performed on two or more pieces, the method developed by the foregoing exercise should always be followed. By carrying all the pieces along together, the work will be most easily and most rapidly accomplished.

145. Smooth Surfaces cannot always be produced by a plane. The presence of knots or a crooked grain causes the work to split in advance of the cutting edge, and a rough surface results. A sharp plane set to take a fine shaving, will do much to remedy this evil, but it cannot be entirely overcome. Surfaces, such as a table top or a door panel, which are not required to be true, may be made as smooth as possible

with a plane, and the rough spots reduced afterwards by means of a hand-scraper, applied as shown by Fig. 164. A surface

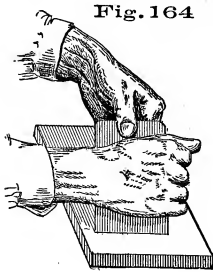

that is required to be true as well as smooth, is best smoothed by a scraper mounted like a plane-iron. Such a scraper may be made to act uniformly over an entire surface, whereas the hand-scraper is useful on rough spots only. The requirement of both truth and smoothness, however, is very unusual. True surfaces are necessary about a

joint, but the parts of a joint are smooth enough as left by a plane. On the other hand, a surface that is required to be perfectly smooth, is one which is made to be seen, and will be sufficiently true if the eye does not detect its inaccuracy.

146. Sand-Papering (103).—The use of sand-paper should be confined to the removal of the minute fiber which is raised and left by the plane. This fiber is usually invisible, but its presence may be detected by comparing a surface newly-planed with a similar surface upon which sand-paper has been judiciously used; the latter will be much smoother. In applying sand-paper, the motion should be “with the grain.” To prevent the destruction of sharp corners or delicate features of any sort, the sand-paper should be held about, or fastened to, a block of wood corresponding somewhat to the form of the work—a flat block for a flat surface, a curved block for a curved surface. A piece of thick leather is sometimes used instead of the wooden block, and is often more convenient, as it may be bent to fit almost any surface.

Sand-paper will not satisfactorily reduce irregularities in a surface, and should never be substituted for the scraper. As has been implied, it will simply remove the fiber, and a few

strokes are generally found to be sufficient ; more are likely to result in injury.

EXERCISE No. 5. — Box.

The stock required is $\frac{7}{8}'' \times 6'' \times 24\frac{1}{2}''$; it must be lined as shown by Fig. 165, and cut into five pieces. The finished box is shown by Fig. 166.

Fig. 165

Scale, $1\frac{1}{2}''=1'$

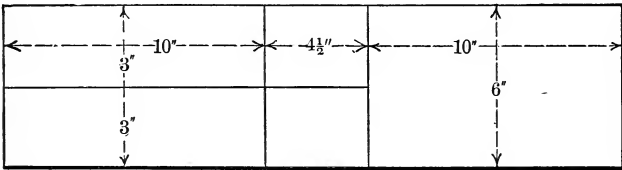

147. If on each of the five pieces there is a surface sufficiently true for a working-face, it should be marked as such ; otherwise, a working-face should be made. From the working-face joint one edge on each piece and mark it as the working-edge. Set the gauge at $2\frac{3}{4}''$ (the inside depth of the box) and gauge the side and end pieces to this depth, after which joint them to line. From the working edge, with the try-square, scribe on the working-face of all the pieces, including the bottom, a line about $\frac{1}{4}''$ from one end. With the back-saw (56) cut these ends, being careful to keep on the outside of the line (148). The work

Fig. 166

Scale, $1\frac{1}{2}''=1'$

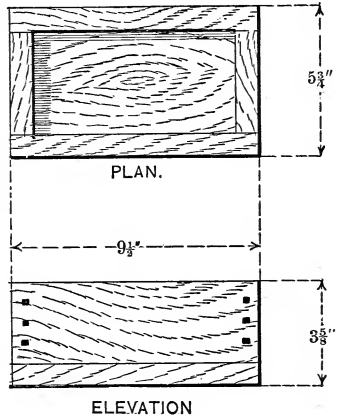

may be held on the bench-hook, as shown by Fig. 167.

In starting the cut, the saw may be made to act across the angle of the work in the direction of the line *ab*, but should gradually be brought to the position shown, its motion being parallel to the face of the work, and its stroke long enough to bring every tooth into action. The position of the saw in Fig. 167, together with the dotted outline, shows a proper range of movement.

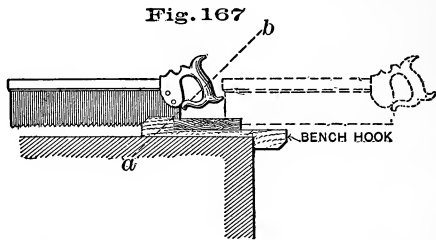

The ends, when sawed, should be square with the working-face and working-edge. If the cut is a poor one, a second may be taken by removing just enough material to hold the saw; if it is only a little "out," it will be best, in this case, to pass the error for a time. One end of each having been squared, the pieces may now be brought to length. On one of the two pieces which are to form the ends of the box, lay off and scribe a line 4" from the squared end. Measure the second end piece by the first to insure the same length for both, whether the measurement is just 4" or not. Next, on one of the two side pieces, $9\frac{1}{2}$ " from the squared end, scribe a line for sawing and, using the first piece as a measure, lay off a similar line on the second side piece and also on the bottom piece. All the pieces having been thus lined, they may be cut with the back-saw, after which all but the bottom piece will be of the dimensions required.

148. Sawing "outside of the line" may be illustrated as follows: if two lines are made on a piece of work just 12" apart, and the portion between cut out by sawing exactly *on* the lines,

it is obvious that the piece will be less than 12" long by half the width of the saw kerf at each end, or, adding the two deficiencies, by the width of one kerf, $\frac{1}{16}$ " or more. The appearance of an end when cut outside of a line will be that shown by Fig. 168. The smooth line along the upper surface, represents the cut made by the scribe in lining the material; the rest shows the work of the saw.

Fig. 168



149. Nailing (254-256). — The side and end pieces are to be nailed, as shown by Fig. 169, three 6-penny casing nails being used at each angle. When brought together, the pieces must be flush — pretty nearly right will not do.

Nails, when seen in a certain position, appear equal in width throughout their length, *A*, Fig. 170; while a view at right angles to the first, shows them wedge-shaped, *B*, Fig. 170. In

Fig. 169

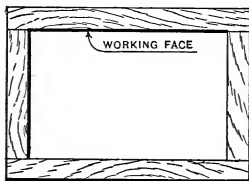

PLAN.

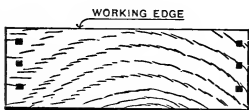

ELEVATION.

Fig. 170

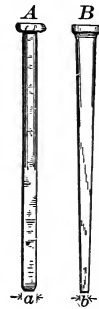

starting a nail, the line represented by *a* must be placed across the grain of the wood, so that the point will cut the fibers which are displaced. If the line *b* is placed across the grain, a few only of the fibers will be severed, and the others will be simply pressed apart by the inclined sides of the nail, an action which is quite likely to split the work.

150. Hammer Marks on the work must be avoided. One who is skilled in the use of a hammer, can drive a nail slightly below the surface of the work without leaving a scar; but it is better to stop driving before the hammer head touches the work than to risk damage.

151. Setting Nails.—When the nail has been driven as nearly “home” as possible, “set” it until the head is at least $\frac{1}{16}$ " below the surface of the work. In applying the set, rest the little finger of the left hand on the work, as shown by Fig. 171, and press the set firmly against it; there will then be no trouble in keeping the set on the head of the nail.

Fig. 171

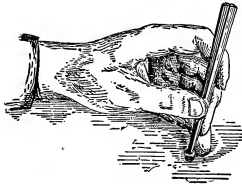

152. Withdrawing Nails.—It sometimes happens that a nail, when partially driven, is found to be tending in a wrong direction, in which case it must be withdrawn. If the hammer, when used for this purpose, is allowed to get into the position shown by Fig. 172, it will mar the work, the nail is likely to splinter the wood around the hole in coming out, and an unnecessary amount of force on the hammer handle is required to draw it. A better way is to keep the hammer from contact with the work by a block of wood, as *a*, Fig. 173. The block-

Fig. 172

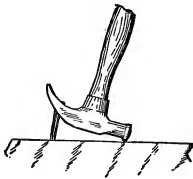

Fig. 173



ing should be increased in thickness as the nail is withdrawn. If the work has been well done, the nail will not be bent.

Never attempt to start a nail in a hole from which one has been withdrawn. The second nail will either follow the first or, prevented from doing this, will take an opposite course no nearer right.

153. Fastening the Box Bottom. — The side and end pieces of a box, when nailed together, may not be exactly rectangular, although each piece has the required length, and the fastening cannot be depended on to retain them with certainty in any given form. But when the bottom piece is added, all parts become fixed. It is, therefore, important that the rest of the box be in proper form when the bottom is nailed.

The bottom piece has been cut the same length as the side pieces, and it has a working-edge with which both ends are square; it is a little wider than is necessary, but this can be made right in finishing the box.

Place the bottom piece with the working-face inside, and the working-edge even with the outside edge of one of the side pieces, as shown by Fig. 174, and drive the nails *a*.

Now since the angles *b* are right angles, the end pieces of the box, in order to be square with the side, to which the bottom is already nailed, must agree with the ends of the bottom piece. If they do not agree, but slip past, as shown by Fig. 174, slight pressure will spring them to place, after which nails may be driven at the points *c*.

The nails in the bottom of a box must be so placed as to avoid those which hold the sides to the ends. No nail can be driven at the corners *d*.

Finishing the box. — With the smooth-plane take a light cut all over the outside, keeping the sides and ends square with the

Fig. 174

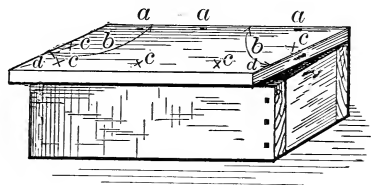

bottom and with each other. The ends of the box, where the end grain of the bottom and side pieces is encountered, present the most difficulty.

154. In planing end grain, the cutting edge must be sharp and set to take a fine shaving. If only a little material is to be taken off, the movement of the plane should be so limited that the cutting edge will not extend beyond the work, two cuts being taken in opposite directions, as indicated by *A* and *B*, Fig. 175. The motion of the plane in both directions,

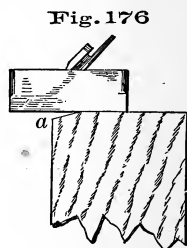
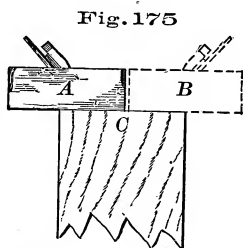

ceases near *C*. If much is to be removed, and it seems best to carry the plane the entire length of the surface, a bevel may be made which will allow the cutting edge of the plane to leave the work gradually, and at a little distance from the edge, as shown by Fig. 176, or a piece of waste material may be fixed with it in the vise as shown by Fig. 179.

EXERCISE No. 6. — BENCH-HOOK (12).

The stock required is $1\frac{3}{4}'' \times 2\frac{3}{4}'' \times 16''$ from Exercise No. 4. It is shown with the necessary lining by Fig. 177, in which figure the Plan, face *A*, represents the working-face, and the Elevation, face *B*, the working-edge. The finished piece is shown by Fig. 178.

155. Lay off the lines *ab* and *cd* on face *B*, Fig. 177. Project *ab* across face *A*, as shown by *ae*, and project *cd* across

face *C* (not shown), and from these, project on face *D* lines similar to *ab* and *cd*, which are already located on *B*. Locate the point *i* on lines *ab* and *cd*, and also on the similar lines of the opposite face *D*, measuring in each case from the work-

Fig. 177
Scale $1\frac{1}{2}''=1'$

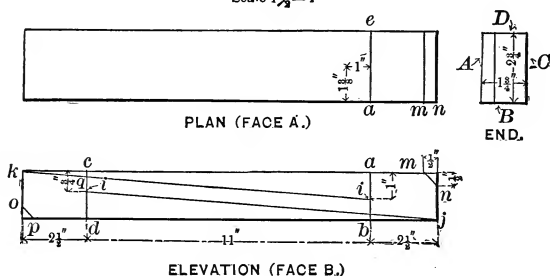
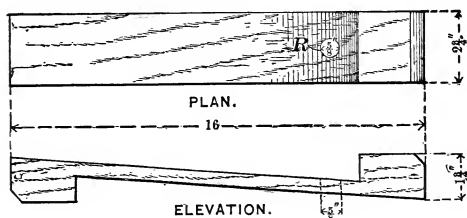

Fig. 178
Scale, $1\frac{1}{2}''=1'$



ing-face *A*, as indicated by the dimensions given. By use of a straight-edge, draw *ij* and *ik*, and similar lines on the opposite face.

Cut along the lines *ij* and *ik* with the rip-saw. There are two ways of starting the saw when the material, as at *k*, is not sufficient to hold the blade. First, a saw cut may be made along the line *cq*, and the triangle *ckq* chiseled out, giving a flat surface, *cq*, on which to begin; secondly, a block of wood of the same breadth with the work may be fastened in the vise

with the latter, as shown by Fig. 179, thus, in effect, extending the surface ok . In the case of the line ik , the second plan is preferable. The block A should bear well upon the work B at k .

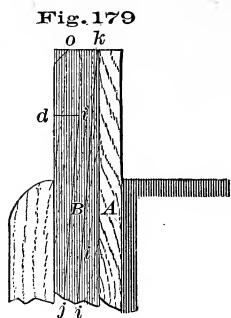

The lines ij and ik having been sawed, cut di and ai with the back-saw. With the chisel produce the bevels represented by mn and op . Bore the hole R , Fig. 178, and the piece is finished.

156. With reference to R , it may be said that while an auger-bit (89) will cut smoothly when entirely within the material, it is sure to splinter when coming out on the face opposite the starting point.

To prevent this, the bit may be used from one side until its spur appears on the opposite side, and then withdrawn, and started in the opposite direction in the hole left by the spur; or the work may be held firmly to another block, as shown by Fig. 180, and the bit allowed to pass into the block as though the two were one piece.

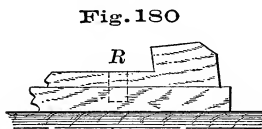

An auger-bit should cut freely, and advance into the work without much pushing on the brace; if it does not, it is in poor condition and should be sharpened.

EXERCISE No. 7. — HALVED SPLICE (202-203).

The stock required is $1\frac{5}{8}'' \times 1\frac{5}{8}'' \times 16''$ from Exercise No. 4; it is shown with the necessary lining, by Fig. 181. The completed piece is shown by Fig. 182.

157. *A* and *B*, Fig. 181, were marked as working-faces when the piece was planed, and may be used as such in this exercise. Midway between the two ends on face *A*, locate the line *a*, and from *a* locate *b*, *c*, *d*, and *e*. Produce each of these lines across all four faces of the piece. Set the gauge at $\frac{13}{16}$ " (half of $1\frac{5}{8}$ " the width of the piece), and from the working-face *A*, gauge a line from *b* on face *B* around the end, and back to *b* on face *D*; also from line *d* on face *B* around the opposite end to line *d* on face *D*. These lines are shown on face *B* by *fg* and *ij*. The joint is made by cutting out the rectangular pieces *bhgf* and *ijkl*.

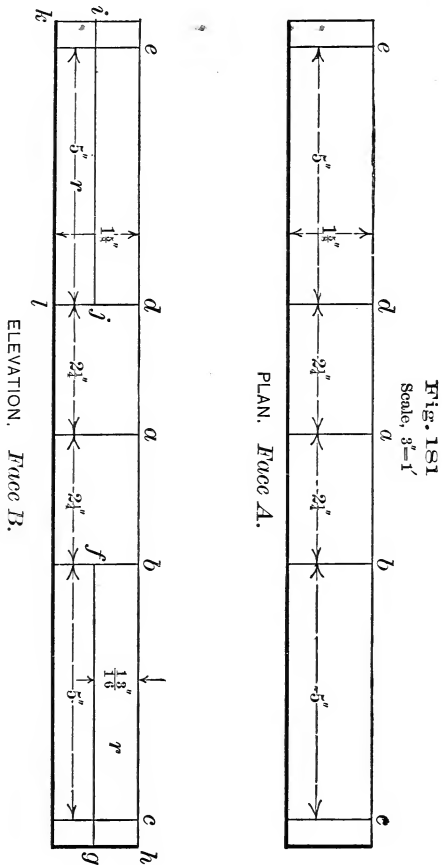

FIG. 181
Scale, 3"=1'

158. In cutting a splice, both pieces are not taken from the same face, for the reason that the gauged line may not be exactly in the middle, and in that case each of the remaining parts would be more than half or less than half the thickness of L. of C.

the material, and their united thickness, when put together, as in Fig. 182, would be greater or less than the material else-

Fig. 182

Scale, 3"=1'

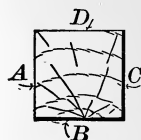
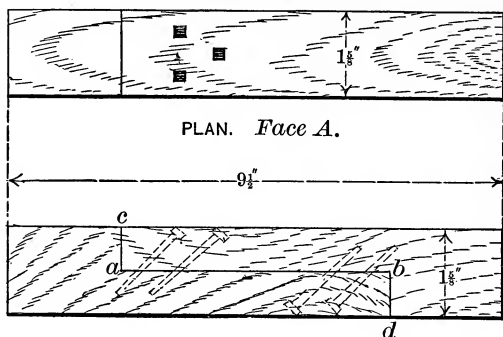

ELEVATION. Face B.

where. The pieces cut out, therefore, are from opposite faces. Then if the gauge line is not in the center of the piece, that is, if *bhgf* is thicker than *ijkl*, the smaller piece will be taken out on one side, and the larger piece on the other; and the sum of the two remaining parts when put together, as in Fig. 182, will be equal to the full size of the material.

159. To cut the pieces, first run the rip-saw down the lines *gf* and *ij*; next, with the back-saw, cut the lines *bf* and *lj*; next the lines *c* and *e*, being careful in all of these cuts to keep the proper side of the line (148). Finally, cut on the line *a*, and try the pieces together as in Fig. 182. If the work has been well done, the joint will be good. If it is not good, the faults may be corrected. The cuts *gf* and *ij*, if not quite to line, may be brought to it by using the chisel as shown by Fig. 147. To facili-

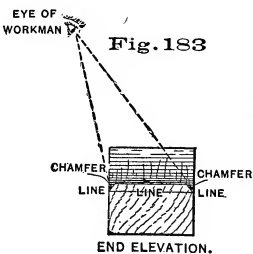

tate the operation, make chamfers on each side from the line to the sawed surface, as shown by Fig. 183, to be used instead of the line. Such chamfers present a twofold advantage; they are both visible from the same point, and they prevent splintering on the side on which the chisel comes out. The fitting on the line ab , Fig. 182, having been finished, suppose that the heading-joint ac fits, but that bd does not; or suppose that neither fits properly, as shown by Fig. 184. If the discrepancy is not great, the joint may be corrected by use of the chisel, or it may be sawed to a fit.

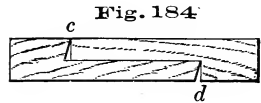

160. "To saw a Fit," the two pieces should be clamped together, or held by hand in the position shown by Fig. 184, and the joint at c sawed into. This will make c at least as wide as the saw kerf. Without changing the relative position of the pieces, turn the work over and saw d , which will also become at least as wide as the saw kerf, and, consequently, equal to c in so far as the joints have been affected by the saw. If in each case the joint is close enough to hold the saw, the pieces after sawing will come together perfectly. If one sawing is insufficient, the pieces may be brought together and sawed a second, and even a third time.

This method of fitting may be widely applied.

When the joint is perfect, the pieces are to be nailed at each

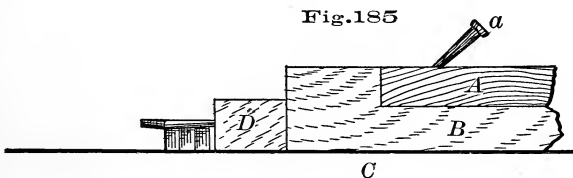

end with 4-penny casing nails driven obliquely, or "toed," as illustrated by Fig. 185. While nailing, rest the pieces A

and *B* on the bench *C*, and, to retain them in position,

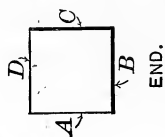

allow one to bear on the block *D*, which in turn is held by the bench-stop. The block protects the ends of the work, which would be mutilated by the bench-stop if they were placed in direct contact with it.

Fig. 186

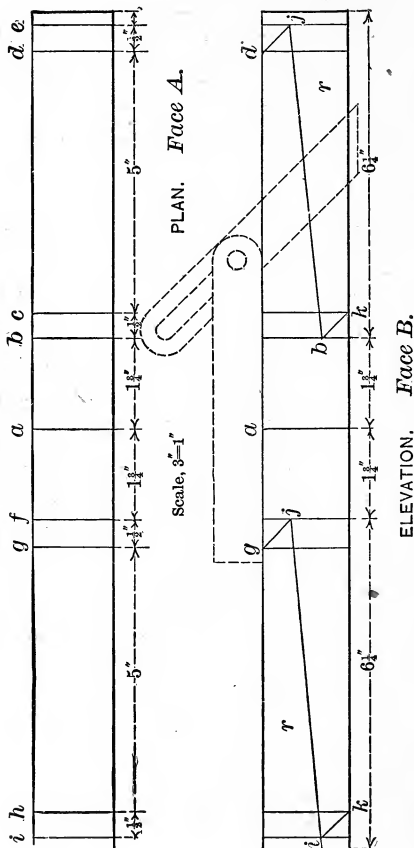

161. Toeing Nails.

—The advantage to be derived from toeing a nail lies in the fact that it always “draws” in the direction in which it is driven. If driven as shown by *a*, Fig. 185, it will draw *A* upon *B* both in a horizontal and in a vertical direction, and will thus insure good contact between the parts of the joint.

The nails having been driven and set, each of the four sides may be given a final smoothing by a stroke of the plane.

EXERCISE No. 8. — SPLAYED SPLICE.

The stock required is $1\frac{5}{8}'' \times 1\frac{5}{8}'' \times 16''$, from Exercise No. 4; the necessary lines are shown by Fig. 186. The finished piece is represented by Fig. 187.

Fig. 187

Scale, 3"=1'

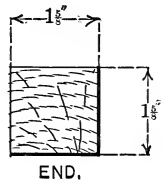
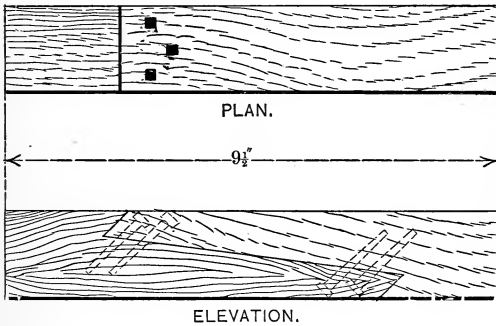

162. Let the faces *A* and *B* be the working-faces. Lay off on face *A* line *a*, and from *a*, the lines *b*, *c*, *d*, *e*, *f*, *g*, *h*, and *i*, and project these lines on all four faces of the work. Set the bevel at an angle of 45 degrees; with its beam on *A*, as indicated by the dotted outline, lay off on *B* lines *dj*, *bk*, *gj*, and *ik*, and repeat these lines on face *D*. Connect points on both *B* and *D*, forming lines which on *B* appear as *bj* and *ij*. The portions marked *r* are to be removed.

Fig. 188

163. To cut the joint, first use the rip-saw on the lines *bj* and *ij*, and afterwards the back-saw on the short oblique lines *gj* and *bk*. The back-saw can easily be started if, while the piece is held in the vise, a stroke is given in the direction *a*, Fig. 188, to carry the saw into the work a distance equal to the depth

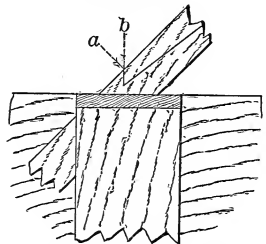

of its teeth, after which it may be turned into the desired direction *b*.

The splayed ends *dj* and *ik* may be cut with the work on the bench-hook, Fig. 189. By following the directions given in the previous exercise the joint may be finished, as shown by Fig. 187.

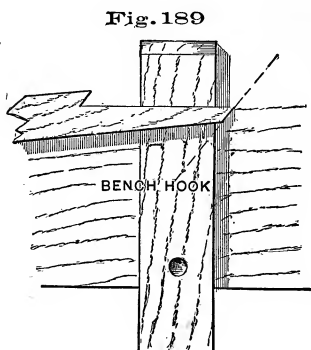

EXERCISE No. 9.—MORTISE-AND-TENON JOINT (211-215).

The stock required is $1\frac{5}{8}'' \times 1\frac{5}{8}'' \times 16''$, from Exercise No. 4 ; it is shown with the necessary lines by Fig. 190. The finished piece is shown by Fig. 191.

164. Let *A* and *B* represent the two working-faces. From one end of the piece, on face *A*, lay off line *a*, and from *a*, lay off lines *b*, *c*, and *d*. Measure carefully the width of the piece on line *d*, face *A*, and lay off one-half of the same on each side of the line *b*, and through the points thus fixed make lines *e* and *f*. Project the lines *a*, *c*, and *d* on all four faces of the piece, and the lines *e* and *f* on *B* and *D*, the two faces adjoining *A*. Set the gauge at $\frac{1}{2}''$, and from face *A*, gauge on *B* the line *gh* and a similar line on the opposite face *D*. Gauge the line *ij* and carry it around the end of the work to the line *d* on face *D*. Set another gauge at $1\frac{1}{8}''$ ($\frac{1}{2}'' + \frac{5}{8}''$, the width of the mortise and of the tenon), and gauge between the same lines as before, pro-

ducing $g'h'$, $i'j'$, etc. The mortise and the tenon are formed by cutting out the portions marked r .

The method of "laying off" the width of the mortise and the tenon is to be especially observed. The distance between the two lines which define the width of the mortise, and those which define the width of the tenon, being equal to the difference in the setting of the two gauges, must be the same. The result, as far as the mortise and tenon are concerned, would not be different if the piece containing the mortise were twice as thick as that carrying the tenon. It is best to use two gauges to avoid the mistakes which might arise from changing a single one. Then, if it should be found necessary to use them after the first lining, precisely the same measurements will be obtained. This process can be short-

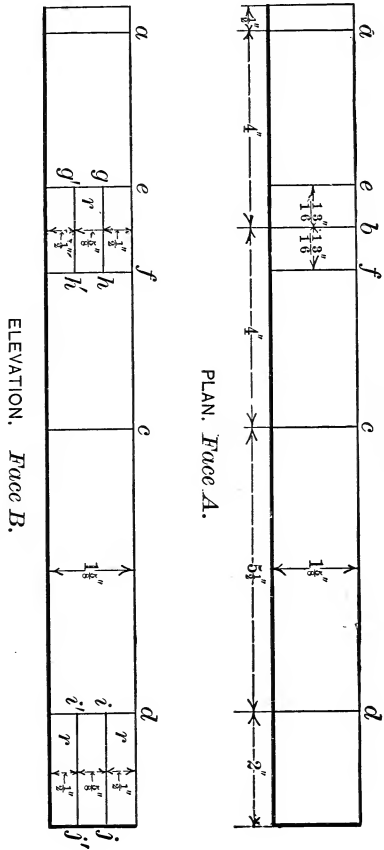
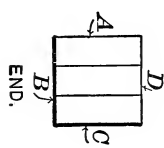
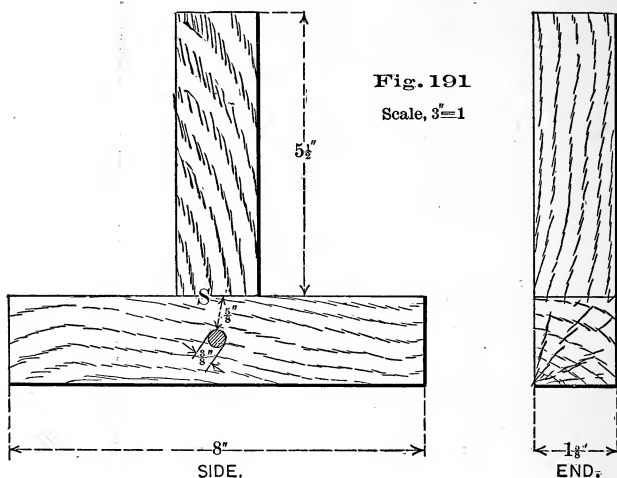

Fig. 190
Scale, 3"=1'



ened by using a mortise-gauge (33), which makes both lines at the same time.

165. **Cutting the Mortise.**—It will be remembered that the lines which appear on face *B*, Fig. 190, have their counterparts



on the opposite face *D*. To cut the mortise, select a chisel having a width as nearly as possible equal to the space between the gauge lines, and, beginning on face *B*, near the middle of the mortise, advance toward one end, as shown by Fig. 149. The end of the mortise having been reached, commence at the starting point and advance to the other end. Always loosen the chisel by a backward movement of the handle; a movement in the opposite direction would injure the ends of the mortise. (See Fig. 149.) After the first few cuts, each deeper than the preceding, the chisel can easily be made to penetrate an inch or more, in pine or poplar. If the depth is equal to half the thickness of the work, no attention need be given to the chips. One side of the mortise having been cut in this manner, turn the work over and repeat the operation on face *D*, the chisel

being driven down to meet the opening made from the first side. After the cutting is finished, the chips may be dug out with a chisel or driven through by use of a wooden plug. Never try to drive them through by using the chisel with its cutting edge parallel to the grain, as such use is very likely to split the work. The chips having been removed, the truth of the mortise may be tested by using the flat side of the chisel as a straight-edge, as shown by Fig. 192. The sides of the finished mortise should agree with the chisel, as at *a*. Compare *a* with *b*. Remember that at least one-half the thickness of the line should remain on the work.

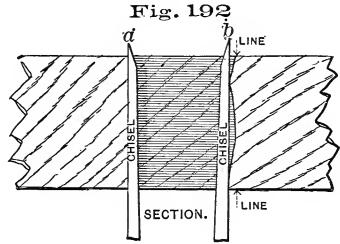

166. The Tenon may next be cut by using the back-saw, both across the grain and with it. The sawing, if to line, leaves nothing to be done except the pointing of the tenon; this is accomplished by a stroke of the chisel on each side, which makes it appear as shown by Fig. 193. The pointing is necessary, because a square-ended, tight-fitting tenon, if driven to place, will splinter the sides of the mortise. The length of the tenon is sufficient to make it project beyond the mortise a distance more than equal to the part pointed. After the fitting has been done, the projecting part is cut off.

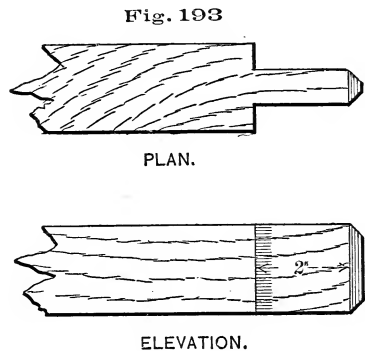

When both the mortise and tenon are finished, cut the piece

on the line *c*, Fig. 190, and try the tenon in the mortise. It should enter at a light-driving fit. If the shoulders of the tenon do not make a good joint with the cheeks of the mortise, that is, if the joint at *S*, Fig. 191, is not good, it may be sawed to a fit, as in the case of the splice. When all is satisfactory, bore the pin hole, insert the pin, cut off the projecting portion of the tenon and of the pin, and take a light shaving from those surfaces on which a plane may be used.

167. To Make a Pin (249).—Select a piece of straight-grained material, in this case 4" or 5" long, and, by use of the chisel, reduce it in section to a square whose side is slightly greater than the diameter of the hole it is to fit. Then take off the corners, making it an octagon in section, and point one

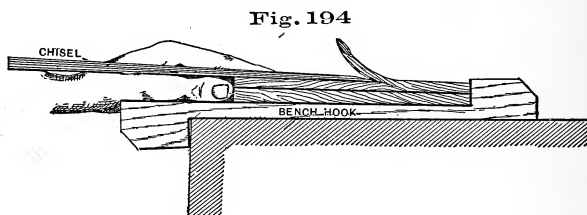

end. All this will be best accomplished if the piece is held by the bench-hook, as indicated by Fig. 194.

168. Drawboring is a term applied to a method of locating

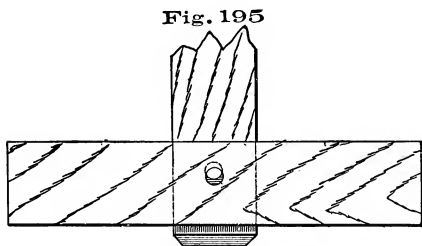

pin holes so as to make the pin draw the tenon into the mortise. Fig. 195 shows the relative position of the holes before the pin is inserted. It is evident that a tight-fitting pin will have a tendency to make the holes in the mortise and tenon coincide, and thus draw the two pieces together. The holes

may be located on the mortise and tenon by direct measurement; or the cheeks of the mortise may be bored through and

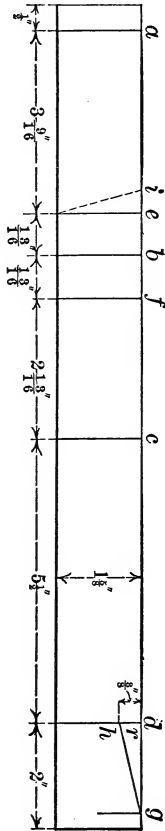

PLAN Face A.

FIG. 108
Scale, 3"=1'

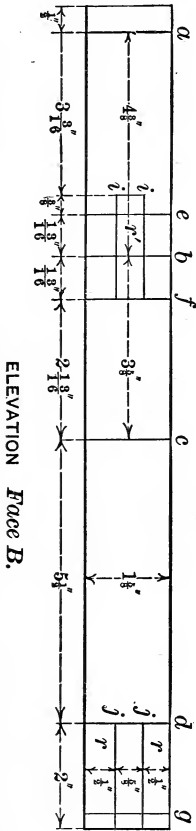

ELEVATION Face B.

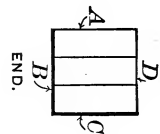

the tenon inserted, and marked by putting the bit into the hole already bored and forcing its point against the tenon. The tenon may then be withdrawn and bored, the point of the bit being placed a little nearer the shoulder of the tenon than the mark.

The practice of drawboring is not to be commended, and, if indulged in at all, great care and discretion must be exercised. In many cases, it puts a strain on the joint which is nearly equal to its maximum resistance, and but little strength is left to do the work for which the joint is made. Frequently, the mortise or tenon is split and rendered practically useless.

EXERCISE No. 10.

KEYED MORTISE-AND-TENON JOINT (240-245).

The stock required is $1\frac{5}{8}'' \times 1\frac{5}{8}'' \times 16''$, from Exercise No. 4 ;

Fig. 197

Scale, 3"=1'

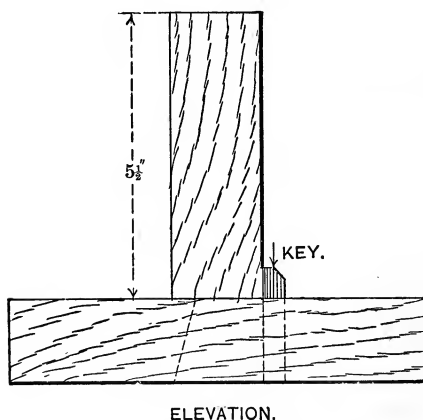
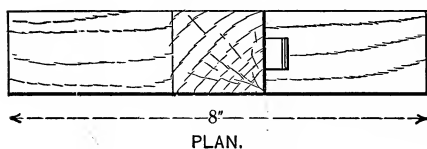

it is shown with the necessary lining by Fig. 196. The finished piece is represented by Fig. 197.

169. The lining differs from that of the preceding exercise in the following respects: the position of the line *b* is changed as indicated by the dimension figures, and the position of lines *e* and *f*, which extend around the piece, is changed to correspond; the mortise is made longer on face *B* than on face *D*, giving one oblique end, as indicated by the dotted line *i*, face *A*.

As regards the tenon, the line g is added at a distance from d equal to the thickness of the piece on the line b , face A ; the point h is located on face A , and on the opposite face C , and the line gh drawn on both faces. The mortise r' is to be cut as in the preceding exercise, and one end made oblique as indicated by the figure.

To form the tenon the portions marked r are to be removed. First, beginning at g , cut along the oblique line gh ; then, beginning at k , the two lines kj ; and, finally, define the shoulders of the tenon by cutting on the line d . This order will save all the lines as long as they are needed.

170. A study of the finished piece will show that the tenon is inserted from the face D , and pushed over so that the splayed edge of the tenon, gh , bears on the splayed end of the mortise, i , leaving an open space at the other end of the mortise to be filled by the key. See Fig. 197.

The key should be planed from a piece 5" or 6" long. It should be uniform in width and nearly so in thickness, there being but a slight taper near the end which is to be driven in advance; this end should be pointed like a tenon. It is best to drive the key from the inside in the direction indicated by the arrow, Fig. 197.

The piece is to be finished in accordance with the appearance and dimensions shown by Fig. 197.

EXERCISE NO. 11. — PLAIN DOVETAIL.

The stock required is two pieces, each $\frac{7}{8}'' \times 3\frac{3}{4}'' \times 4''$, edges jointed parallel, and one end squared. (The material may be worked up as one piece $\frac{7}{8}'' \times 3\frac{3}{4}'' \times 8''$, which, after being planed to width, may be cut in two with the back-saw, thus giving the squared ends required.) The working-faces used in preparing the material may also be used in laying off the lines. To avoid confusion one piece will be called X and

the other *Y*. Fig. 198 shows the lining necessary for *X* and *Y* respectively. The finished joint is shown by Fig. 199.

171. Lay off on all four faces of each piece, $\frac{7}{8}$ " from the squared end, the line *ab*, Fig. 198.

Fig. 198
Scale, $\frac{3}{8}''=1'$

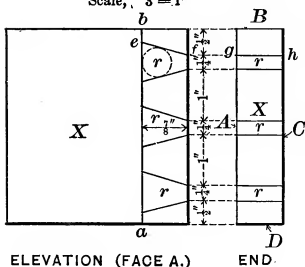

ELEVATION (FACE A.)

END.

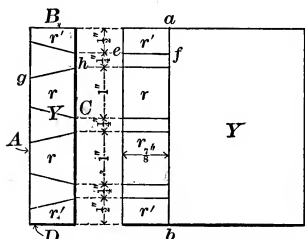

END.

ELEVATION (FACE C.)

Fasten *X* in the vise, and on its squared end lay off lines as *gh*, Fig. 198. Remove the piece from the vise, and with the bevel set "1 to 4" (29), project on the faces *A* and *C* oblique lines as *ef*. The portions which are to be removed to form the mortises, are marked *r*. Put the piece in the vise again, and with the back-saw cut down the oblique lines as *ef*. With a chisel, used as in cutting an ordinary mortise, remove the material between the lines. If preferred, part of it can be removed by boring a hole as indicated by the dotted outline. The hole will make the chiseling easier,

but in so small a piece of work it is doubtful whether there is anything gained. The piece *X* having been finished, fasten *Y* in the vise, working-end up and working-face outward. Place the working-face of *X* on the working-end of *Y*, as shown by Fig. 200, taking care that the line *ab* on *X* is in the same line with the working-face of *Y*. Holding the work in this position, and guided by the mortises in *X*, scribe on the end of *Y* the oblique lines as *gh*, Fig. 198. Remove *Y* from the vise, and with the beam of the square on the working-end, project to *ab* lines as *ef* from the extremities of the oblique lines just made. The portions marked *r* and *r'* are to be removed to form the

“pins.” Those on the outside marked r' may be removed entirely with the saw; those on the inside (r), partly with the chisel, as in the case of the mortises in the piece X .

172. The joint ought to go together by light driving, and

Fig. 199
Scale, $3''=1'$

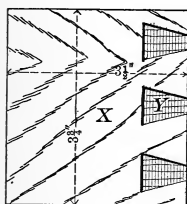
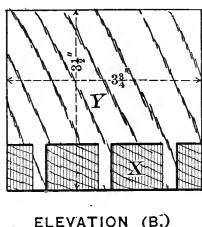
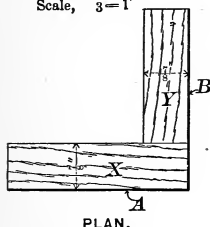

ELEVATION (A.)

be perfectly square on the inside between the working-faces. If it is found to be satisfactory, take it apart, apply a light coating of glue, and drive together again. When the glue is hard, the joint may be smoothed and squared, and the ends of the pieces cut to the dimensions shown in Fig. 199.

173. It will be seen that one part of the joint is made, and the second part is then made to fit the first; hence, the proportions of the first part need not be

determined with great exactness. The skilled bench-worker usually proceeds as follows: on the piece X (if there are several pieces, X , he treats them all at the same time) he lays off the lines ab and cross-lines as gh , the latter without measuring, and then saws obliquely without the use of lines as ef ; on Y he lays off the lines ab and oblique lines as gh , and saws without making lines as ef . In this way the joint is soon made, and, although not perfectly symmetrical, it may be well-formed and well-fitted.

Fig. 200

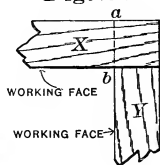

EXERCISE NO. 12. — LAP, OR DRAWER, DOVETAIL.

The stock required is one piece $\frac{7}{8}'' \times 3\frac{3}{4}'' \times 4''$ and one piece $\frac{1}{2}'' \times 3\frac{3}{4}'' \times 4''$, edges jointed parallel and one end of each squared. The finished piece is shown by Fig. 201. It will be seen that the piece *X* does not extend across the full thickness of the

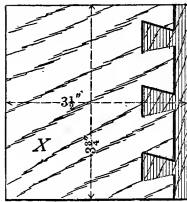
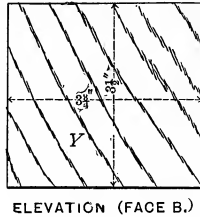
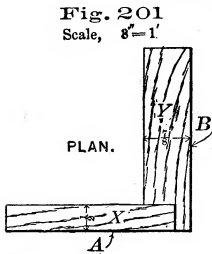

ELEVATION (FACE A.)

piece *Y*, and, consequently, the end grain does not appear in Elevation *B*, Fig. 201.

174. On *Y*, Fig. 202, scribe the line *ab*, $\frac{1}{2}''$ (the thickness of *X*) from the working-end, and continue it across the working-edges. Set a gauge at $\frac{5}{8}''$, and from the working-face *A* gauge the line *cd* on the working-end, and extend it on the edges until it meets the extended line *ab*, as shown by face *D*, Fig. 202. From the working-end of *X*, with the same gauge, make the line *ab* on the two faces *A* and *C*. Produce the remaining lines on *X*, cut the mortises, and lay off *Y* by *X*, as in the last exercise.

Fig. 202
Scale, 8"=1'

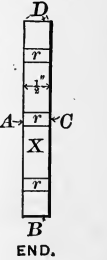
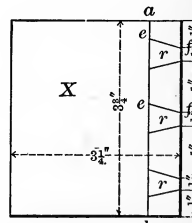
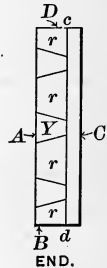
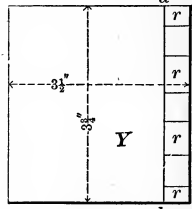
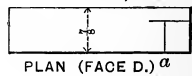

In cutting out around the pins (*Y*), the delicacy of the work does not demand the most delicate chisel, but one as large as is convenient should be used. Finish the joint to the dimensions given by Fig. 201.

EXERCISE No. 13. — BLIND DOVETAIL.

Fig. 203
Scale, 3"=1'

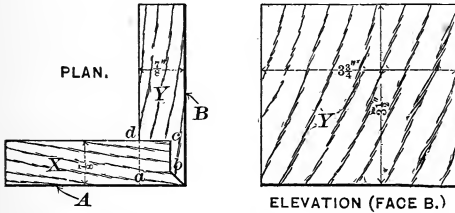

The stock required is two pieces, each $\frac{7}{8}'' \times 3\frac{3}{4}'' \times 4''$ edges jointed parallel and one end squared. The finished joint is shown by Fig. 203. The dovetail is wholly within the square *abcd*, and, consequently, no end grain shows on any face.

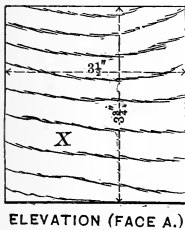

175. With the square, lay off on the working-faces and two edges of each piece of material, Fig. 204, the lines *ba*, *ai*, and *cd*, *dk*, and from the working-face *A* gauge on the ends of each piece the line *ef*.

Fig. 204

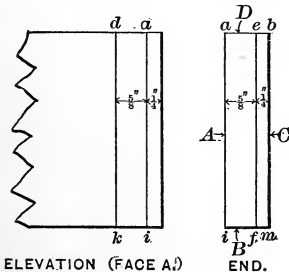
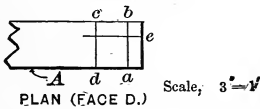
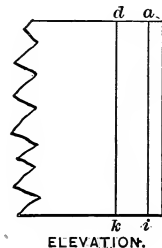
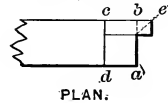

Fig. 205

Scale, 3"=1'



Cut both pieces as shown by Fig. 205. Taking one of the pieces, which will be called *X*, space¹ and lay off on the reduced end surface lines as *op*, Fig. 206, using the try-square blade as indicated by the dotted outline. Next, produce oblique lines as *gh*, shown in the same figure, and cut the mortises marked *r*.

Fig. 206
Scale, 3"-1'

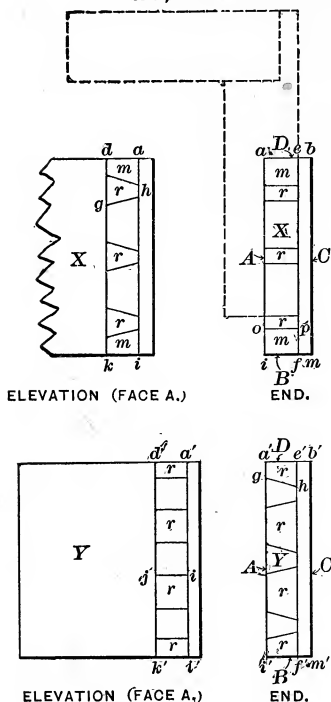

With *Y* in the vise apply *X*, in which the mortises have already been cut, as shown by Fig. 207, so that points may be located along the exterior angle *e'* of *Y*, corresponding to the openings in *X*. Project these points (shown on line *e'f'*, Fig. 208) from the exterior angle *e'*, to the interior angle *b'*, Fig. 207. Next apply *X* to *Y*, as shown by Fig. 209; from this position the points shown on the line *a'i'*, Fig. 208, can be secured along the angle *a'*. These points, when connected, will give lines as *gh*, *Y*, Fig. 206. From these lines, project on the working-face lines as *ij*, down to the line *d'k'*. Cut out the portions marked *r*, and the dovetail is finished. It now remains to make a miter-joint between the two rectangular projections on *X* and *Y*. Set the bevel at a miter (an angle of 45

¹ No dimensions are given for locating the lines similar to *op*, *X*, Fig. 206. They can be found by measuring the drawing, which, as indicated by the scale, is one-fourth the size of the piece it represents.

degrees) and scribe the dotted line e , Fig. 205, on each piece; then cut to line with a chisel. When the joint has been fitted, glue, and finish to dimensions.

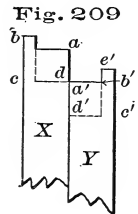
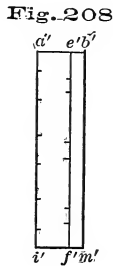
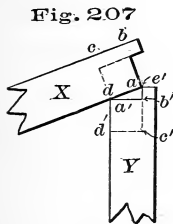

176. If, instead of cutting out the first and last space of Y , one-half only is cut out, as shown by Fig. 210, the dividing line being on a miter, and, if the outside portions of X , m , m , Fig. 206, are cut away to a miter to correspond, the joint will appear as a plain miter-joint, instead of that shown by Fig. 203.

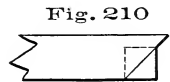

EXERCISE NO. 14. — FRAME AND PANEL (246-248).

177. Fig. 211 shows a small panel door. The frame is made up of stiles and rails, which are fastened together by mortise-and-tenon joints; the spaces within the frame are filled by panels. The lower panel is simply a thin board screwed to the back of the frame. The upper panel is composed of narrow strips, which are inserted in a groove made in the frame for their reception. The front of the frame, around the lower panel, is chamfered, and around the upper panel is beaded. It is the purpose of this exercise to construct that portion of the door included within the rectangle $abcd$.

Three pieces of stock are required, each jointed to dimen-

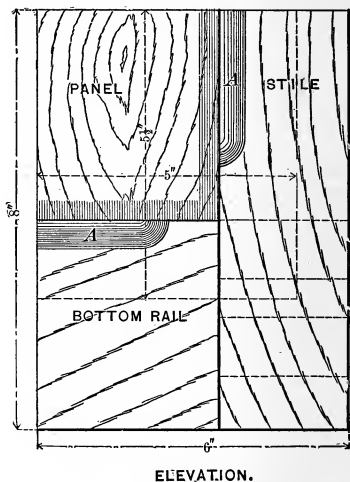
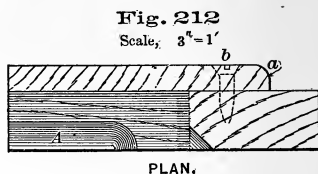
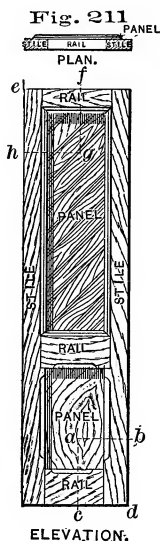

sions as follows : for the stile, $1\frac{1}{8}'' \times 2\frac{1}{2}'' \times 9''$; for the rail, $1\frac{1}{8}'' \times 4'' \times 6\frac{1}{2}''$; and for the panel $\frac{1}{2}'' \times 5'' \times 5\frac{1}{2}''$. The finished work is shown by Fig. 212.

178. The mortise-and-tenon joint between the stile and rail, both in the size and position of its parts, is shown by Fig. 213. The width of the mortise and the tenon should be equal to the width of the $\frac{3}{8}''$ chisel.¹ It will be noticed that the lines are so placed as to make the stile extend beyond the lower edge of the rail. This extension, or "horn," as it is called, is for the

¹ The nominal width of a chisel does not always agree with its actual width.

purpose of re-enforcing the end of the mortise during the fitting, — a recourse which must always be had when the mortise in the finished work closely approaches the end of the material. After all the jointing has been done, the horns may be cut off. Having laid off the necessary lines for cutting the mortise and the tenon, very light lines, as cd and $c'd'$, Fig. 213, should be made on both stile and rail to guide in cutting the chamfers.

Fig. 213
Scale, 3"=1'

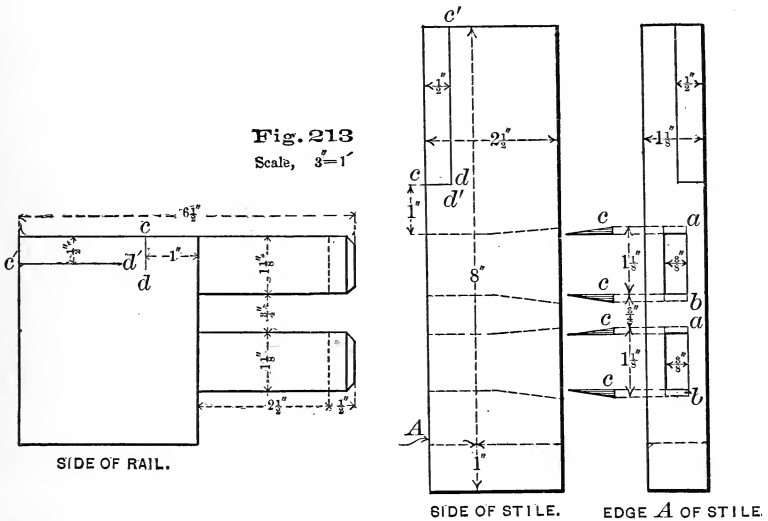

Cut and fit the mortise and tenon, and then make both chamfers, as shown in the finished piece, Fig. 212.

179. Short chamfers (222, 223) like these are best cut by use of the chisel, a spokeshave sometimes being used in finishing.

Long chamfers may be cut rapidly by the drawing-knife, which may be followed by the smooth-plane.

180. Before putting the joint together, enlarge the outside end of each mortise, as shown by a and b , Fig. 213, to make room for the wedges c , c , which, after the joint has been

driven together, are to be dipped in glue and driven as indicated. This method of wedging forms a very strong joint (250, 251).

181. Round the edge of the panel on the bottom and side, as shown by *a*, Fig. 212, and fasten it to the back of the frame by two 1" No. 8 screws — one in the rail, and one, *b*, in the stile (258).

182. In inserting screws, the outside piece (in this case the panel) must be bored for each screw. The hole should be sufficiently large to allow the screw to pass through easily; and, if the wood is hard, it must be enlarged at the top, or "counterbored," to receive the head of the screw. The piece in which the screw holds (in this case the frame), if of soft wood, need not be bored unless there is danger that it may split, in which case a hole should be made, in diameter about two-thirds that of the screw. The necessity for a hole in hard wood depends largely on the proportions of the screw. A short, large-wired screw will stand almost any service, while a long slender one will frequently be twisted or broken under the strain necessary to drive it into wood which is only moderately hard.

Judgment must determine when the screw is driven sufficiently. The head must bed well into the wood; but there is danger that it may be forced so far as to "strip" the thread, and that, as a consequence, the screw will not hold (96, 98).

Never allow the screw-driver to slip from the slot of the screw while the latter is being driven.

183. Brad-awls are useful in preparing the way for small screws. The cutting edge should always be placed across the grain so that the fibers will be cut, and not simply pressed apart to close up again when the tool is withdrawn. The difference

in effect may be seen by comparing, Fig. 214, *A*, which shows a proper action, with *B*.

Fig. 214

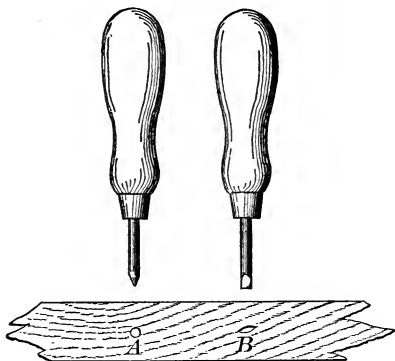

EXERCISE NO. 15.—PANELING.

This exercise consists in making that portion of the panel door, Fig. 211, included within the rectangle *efgh*.

Fig. 215

Scale, 3" 1'

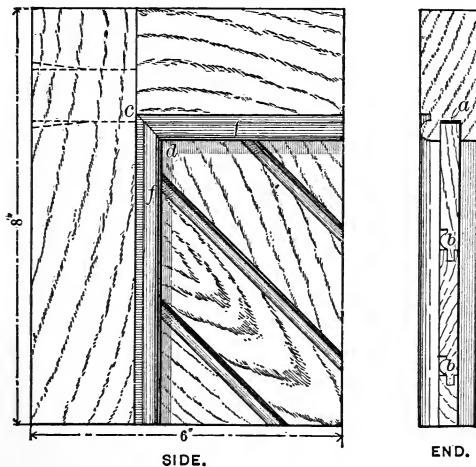

Three pieces of stock are required, each jointed to dimensions as follows: stile $1\frac{1}{8}'' \times 2\frac{1}{2}'' \times 9''$; rail $1\frac{1}{8}'' \times 2\frac{1}{2}'' \times 6\frac{1}{2}''$; panel strip $\frac{1}{2}'' \times 1\frac{3}{4}'' \times 18''$. The completed exercise is shown by Fig. 215.

184. In considering the joint between the stile and rail as shown by Fig. 216, three new features will be observed; the groove, or "plow," which is to receive the panel, as shown at *a*, Fig. 215; the beads *f, f*; and the mitered corner *cd*, which allows the parts to be plowed and beaded as shown, without affecting the mortise-and-tenon joint.

Follow the dimensions, and line for the mortise and tenon as in the preceding exercises, supposing the rail to be of the form indicated by the dotted outline *d'jc'*, Fig. 216, and the stile to be of the form indicated by *efd*. This done, add the lines *ec*,

Fig. 216
Scale, 3"=1'

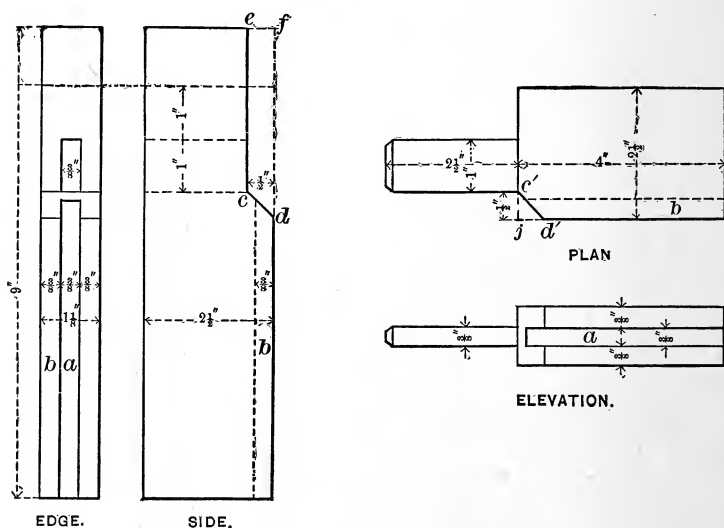

cd, and *c'd'*, by means of gauge and bevel. Cut the mortise and the tenon, after which plow the groove *a*.

185. No special direction can be given for using the plow (85), except that it is to be used from the working-edge; but it will be safe to practice with it on a piece of waste material before applying it to the work.

Fig. 217
Scale, $3''=1'$

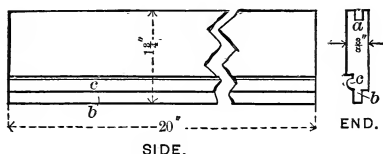

186. Next, the beads *f, f*, Fig. 215, are to be formed on the inside edge of both rail and stile, that is, along the edges marked *b*, Fig. 216. What has already been said regarding the use of the plow, may also be said of the beading-plane (84).

The mitered corners are now to be formed by cutting with the back-saw to lines already made, and then the joint between stile and rail, fitted and wedged as in Exercise No. 14.

The frame having been made ready, attention may be given to the panel. The panel strip, already jointed, must be "matched" by forming the tongue *b* and the groove *a*, Fig. 217. This operation brings into use the $\frac{1}{2}''$ matching-planes (82), which should first be tried on a piece of waste material. The bead *c*, Fig. 217, is to be made with a $\frac{3}{16}''$ beading-plane.

Fig. 218
Scale, $3''=1'$

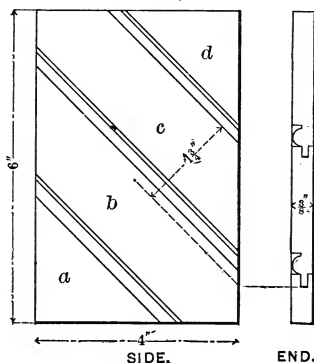

Cut the panel strip into lengths suitable for forming the complete panel, Fig. 218, using either the bevel or the miter-

box in obtaining the angle of the ends. The fitting of the pieces one to another will be most easily done if they are cut in order, as *a*, *b*, *c*, etc.

187. In using the miter-box, Fig. 219, the work *a*, while resting on the bottom of the box, must be pressed against the side *b*, in which position, the saw, guided by the box as shown, will cut the piece at a miter. The opposite guide *c* may be used in the same manner. By using *d* the work will be cut off

Fig. 219

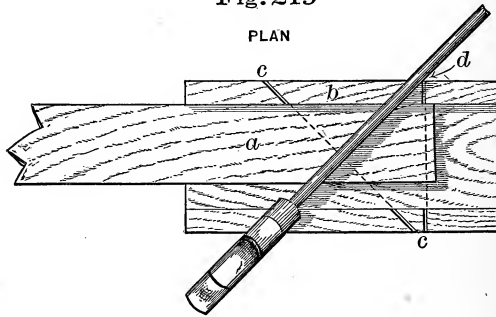

square. To hold the pieces of the panel together, and to fasten the panel to the frame, light brads may be inserted in the oblique ends of the panel strips shown at *b*, Fig. 215, or, what is, perhaps, better, glue may be used. If the door were complete, as shown by Fig. 211, the panel would have perfect support in the frame.

PART III.



ELEMENTS OF WOOD CONSTRUCTION.

TIMBER.¹

188. “**Timber** is that portion of the woody material of trees which is used in carpentry and joinery.” “If the trunks of timber-bearing trees are cut, they are found to be composed of concentric cylindrical layers, whose cross-sections form rings, separated from each other, and evidently quite distinct. These layers [Fig. 220] are formed, one each year, during the period of growth of the tree. They vary in thickness, in density, and in color, according to the rapidity of growth, the length of the season, and other circumstances which may change from year to year.

Fig. 220

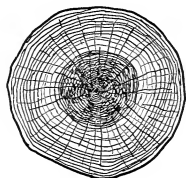

“The outer portion of the trunk is called the ‘*sap-wood*,’ and it is usually lighter in color, and less strong and dense than the interior portions, or *heart-wood*.”

“The circulation of sap through the sap-wood occurs during favorable weather. In winter it is supposed to cease, and this period of checked circulation causes the lines of demarkation between successive annual rings.”

¹ Quotation marks under this heading refer to Thurston's “Materials of Engineering,” Part I.

“The heart-wood is nearly or quite impervious to sap, its vessels being closed up, and the wood is dense and hard.” It is usually far more durable than sap-wood.

“Different kinds of trees, and different individuals of the same species, have different proportions of sap-wood. The slower-growing trees usually contain the least.”

189. “**Felling' Timber** should always, if possible, be practiced at the period of maturity; if earlier, the wood will not have acquired its greatest strength and density, and will contain too great a proportion of sap-wood; if later, the wood will have become weakened by incipient decay.

“The oak is said to reach maturity when about 100 years of age, and it should not be felled at less than 60.

“Pine timber should be cut at from 70 to 100 years of age, and ash and elm, at from 50 to 100.

“The season of the year best adapted to felling timber is either midwinter or midsummer. The months of July and August are often selected, as at those seasons the sound trees remain green, while the unsound trees are then turning yellow. Healthy trees then have tops in full foliage, and the bark is uniform in color, while unsound trees are irregularly covered with leaves of varying color, having a rougher, and often a loosened, bark, and decaying limbs.”

After felling, “the trunk should be immediately stripped of its bark, and, when heart-wood only is wanted, the sap-wood removed as soon as possible. The bark is often removed from trees in spring, and the felling deferred till autumn or winter. This is probably the best course to pursue, usually.”

190. “**Seasoning Timber** is simply driving out the sap from its pores by either natural or artificial means. This should always be done as gradually as possible, otherwise the timber is liable to crack or ‘check,’ from irregular drying.

“Natural or air seasoning gives the best results. The timber

should in all cases be squared as soon as cut, and all large logs should be halved, or even quartered. It is then piled in the seasoning yard in such a manner as to be protected as far as possible from the sun and rain. It should be placed where the air may circulate freely on all sides, not only of the pile, but of each log; bad ventilation is sure to cause rot. After remaining thus for some months, the logs may be cut into smaller joists, if needed in such form, or into planks and boards, and again piled for further seasoning.

“For heavy work two years, and for lighter work, four years, is sufficient time for seasoning boards; but timber is rarely overseasoned.”

Artificial methods of seasoning by means of high temperature, are much more rapid in operation than the natural method just described. It is not impossible, in this manner, to season one-inch material in two days.

191. Shrinkage in timber occurs whenever it loses moisture. In the process of seasoning, shrinkage may reduce the width and thickness of a timber fully “eight per cent,” but it has little effect on its length. Wood cannot be so well seasoned as not to shrink whenever the surrounding dryness is increased. It also has a tendency to shrink after having its surface removed, by a plane, for example. This is due to the reopening of the pores, which in the fibers of the old surface had become closed by contraction; in this way new passages are afforded for the escape of moisture.

192. Swelling occurs whenever the timber absorbs moisture. Most woods give up moisture more readily than they receive it, and, therefore, a timber will not swell so much when transferred from a dry atmosphere to a moist one, as a similar timber will shrink when transferred from a moist atmosphere to a dry one, the difference in the atmospheric conditions being the same. A slight change, however, in the amount of surrounding

moisture is sufficient to produce a perceptible change in the dimensions of a piece of wood. As a rule, the softer a wood is, the more readily it shrinks and swells.

193. Warping in wood is a change of form resulting from unequal shrinkage or swelling.

Suppose Fig. 220 to represent the end of a log. It will be seen that, besides the lines defining the annual ring layers, there are others extending from the center in all directions; these are known to the botanist as *medullary rays*, and sometimes to the carpenter as *silver rays*. In some woods, they are very clearly defined; in others, they are hardly discernible. The medullary rays serve to bind together the annual ring layers, and are not very much shortened by shrinkage. In seasoning, the outer ends draw together, as at *A* and *B*, Fig. 221, and

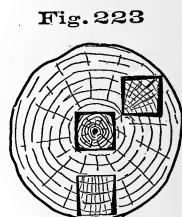
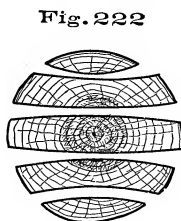
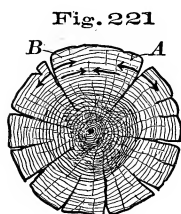

produce ragged cracks, which sometimes extend from the exterior to the heart-wood, as shown.

194. If a log is cut longitudinally into five pieces, the middle piece will, in shrinking (by the drawing together of the medullary rays), become thinner at the edges than at the center, as shown by Fig. 222. The other four pieces will warp as shown, the surface of each piece, which in the log was nearest the center, becoming the convex side after shrinking.

The shrinkage of a square joist will vary according to its position in the log relative to the heart. (See Fig. 223.) Thus, it will be seen that, in the cross-section of a timber, changes

resulting from shrinkage can be foretold whenever the character of the end grain can be determined.

195. Timbers also warp in the direction of their length. When not due to the subjection of one part to dryness or dampness to the exclusion of other parts, this can be traced to unevenness in the grain, which exposes a greater number of fiber ends in one part of a surface than another. The more fiber ends there are on a surface, the more readily moisture will pass into or out of the wood, and the more pronounced will be the local shrinking or swelling, and consequent warping. For example, suppose Fig. 224 to represent the edge of a board having the grain as shown.

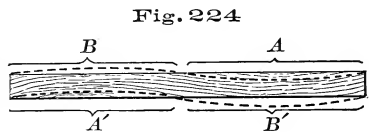

Moisture will escape more readily from the surfaces marked *A* and *A'* than from those marked *B* and *B'*. The contraction of the surfaces *A* and *A'*, will force the board into the shape shown by the dotted line.

The most fruitful cause of warping, however, is unequal exposure. One side of a board may be exposed to the sun while the other is protected from it; the side exposed will be found concave, both in length and breadth. Heat from a stove or dampness from the ground are common causes of warping.

If a board newly planed on all its faces, is left flat on the bench, it will after a time be found concave in its upper surface, a result due to the greater exposure of the upper surface as compared with the lower, which remained in contact with the bench. A piece having reasonably straight grain, and which has been planed all over, should be left on its edge or end. Pieces of irregular shape, that are required to be made to form accurately, are best when cut roughly almost to the required dimensions, and allowed ample time to shrink and warp before being finished exactly to size.

CARPENTRY.¹

196. It is the work of the carpenter to raise and inclose the frame of a building, to construct its floors and roofs, and to complete all parts which give stability to the structure; the joiner makes the doors and windows, erects the stairs, and provides such interior woodwork as will finish the building as a habitation. A single mechanic may perform almost every kind of work required in the construction of a building, thus eliminating this distinction of trades; but for convenience in classification, we may imagine the work of the carpenter and that of the joiner to be quite distinct.

It will be understood that neither carpentry nor joinery is confined to house-building. While all bench work may properly be classed as joinery, it involves forms and principles that are the logical outgrowth of carpentry. For this reason, in the following consideration of *joints*, there are presented, first, those belonging to carpentry, which will include such as are used in uniting timbers, as in a frame for a building; and, secondly, those belonging to joinery, which will include such as are used in joining small planks or boards. This classification cannot be rigidly adhered to, but it will serve the purpose of the following pages.

197. Any two timbers may be united in the direction of their length, or they may be united at an angle.

Timbers united in the direction of their length are usually

Fig. 225

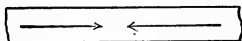
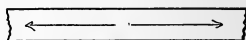

Fig. 226



subject to *compressional strain*, which has a tendency to reduce their length, as indicated by Fig. 225; or *tensional strain*,

¹ Tredgold's "Carpentry," and "Notes on Building Construction" published by Rivingtons, have furnished many of the facts presented under Carpentry and under Joinery.

which has a tendency to increase their length, Fig. 226; or *cross-strain*, which has a tendency to bend them, Fig. 227; or to two of these strains at the same time.

198. **A Timber** subjected to cross-strain must always bend.

The fibers forming that surface which is convex or has a tendency to become so (as the lower surface, *A*, Fig. 227) will be subject to tensional strain, while the fibers forming the opposite surface will be brought under compressional strain. This is shown by Fig. 228, *A* representing a straight

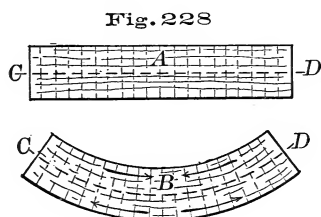
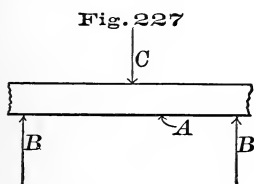

timber, and *B* the same timber bent. It follows, then, that somewhere between the compressed surface and the extended surface there will be a line which is subject to neither compressional nor tensional strain; such a line is called the *neutral axis* of a timber, and will be located with sufficient accuracy for the purposes of this work, if drawn midway between the upper and lower surfaces, as shown by the dotted line *CD*, Fig. 228.

In the timber that has been forced into a curved form, Fig. 228, the fibers within the neutral axis are under no strain excepting that required to hold the compressed portion to the extended portion; but the conditions are found to change rapidly as the examination extends to fibers more and more remote from this axis. In other words, the strength of such a timber increases rapidly as its depth increases. For example, if Fig. 227 represents a 2" \times 4" timber (2" wide and 4" deep) supported at *B*, *B*, and capable of sustaining 200 pounds at *C*,

it can be shown that, if the depth is doubled, leaving the width the same, by substituting a 2" \times 8" timber, it will sustain four times the original load, or 800 pounds; while if the width is doubled, leaving the depth the same, by substituting a 4" \times 4" timber, it will sustain only twice the original load, or 400 pounds. The law is that the strength of timbers subject to cross-strain, varies as the width, and as the *square* of the depth.¹

199. Rankine has given five principles to be observed in designing joints and fastenings. They are as follows:—

1. "To cut the joints and arrange the fastenings so as to weaken the pieces of timber that they connect as little as possible."

2. "To place each abutting surface in a joint as nearly as possible perpendicular to the pressure which it has to transmit."

3. "To proportion the area of each surface to the pressure which it has to bear, so that the timber may be safe against injury under the heaviest load which occurs in practice, and to form and fit every pair of such surfaces accurately, in order to distribute the stress uniformly."

4. "To proportion the fastenings so that they may be of equal strength with the pieces which they connect."

5. "To place the fastenings in each piece of timber, so that there shall be sufficient resistance to the giving way of the joint by the fastenings shearing or crushing their way through the timber."

Complicated forms of joints are likely to violate Rule 3.

¹ By what has been given, it will be seen that in any body of material the portions most affected in resisting cross-strain are those lying near the upper and lower surfaces, Fig. 227. In view of this fact, parts that are to receive a cross-strain, especially if of iron, are, in important structures, formed to present a large amount of material near these surfaces. A railroad rail or an I-beam are simple illustrations; a bridge truss is an elaboration of this principle.

JOINTS CONNECTING TIMBERS IN THE DIRECTION OF THEIR
LENGTH.

200. **A Lapped Joint**, shown by Fig. 229, fastened either by straps *A* or bolts *B*, is clumsy, but very strong.

201. **A Fished Joint** in its simplest form is shown by Fig. 230, and is so called because of the two pieces marked *A* called "*fish-pieces*" or "*fish-plates*."

Fig. 229

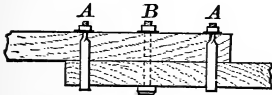
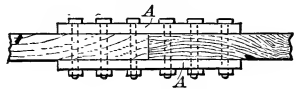

Fig. 230



Fish-pieces may be of either wood or iron, and may be employed to form the fished joint shown in Fig. 230, or applied to more complicated joints to increase their strength.

When subject to compressional strain, a fished joint should have four plates, one on each face. When subject to tensional strain, the plates, if of iron, may be indented, *A*, Fig. 231; or, if of hard wood, the ends may be tabled, *B*, Fig. 231, or keys inserted as shown by *A* and *B*, Fig. 232. Other things being

Fig. 231

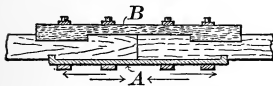
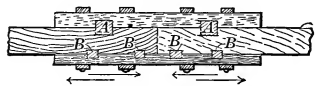

Fig. 232



equal, if the number of keys is doubled, the thickness of each may be diminished one-half without reducing the strength of the joint, since the total amount of abutting surface will remain the same.

NOTE.—The student should observe carefully the position of the lines in the following representations of joints, so that he may clearly see the reasons for the different methods of construction. He should first look for the abutting surfaces, and then note their relation to the rest of the joint.

For cross-strain, the fish-pieces should be on the sides of the joint, as shown by Fig. 233.

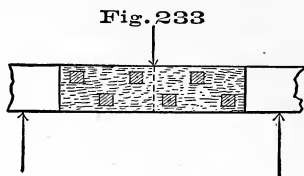

The bolts used for securing fish-pieces, or employed as fastenings for any joint, should be placed checker-wise, Fig. 233, so that no two will cut the same cross-section.

Fished joints are often used in heavy construction. By a suitable proportion of parts, the joint can be made almost as strong as the timbers it connects.

202. Scarfed Joints are those in which the two timbers united are so cut and fitted as to make the joint uniform in size with the timbers. In determining the form of any scarf, the principles already given (199) should be adhered to as closely as possible. Some scarfs by their form are self-sustaining, but, compared with the timbers they unite, are weak, and are seldom used unless strengthened by bolts, or by bolts and fish-pieces.

203. *A scarfed joint for resisting compression* is shown in its simplest form by Fig. 234. When strengthened by bolts and fish-pieces, it forms an exceedingly good joint.

Fig. 234

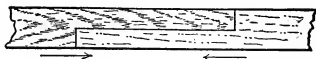

Fig. 235



204. *A scarfed joint for resisting tension* is shown by Fig. 235. The key *A* supplies the abutting surface to receive the strain tending to open the joint; in thickness it is equal to one-third that of the timber. In practice this joint is not often

employed without fish-pieces. Fig. 236 shows a modification of 235, which will serve excellently for tensional strain.

Fig. 236

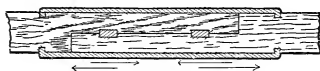

205. A scarf joint for resisting cross-strain is subject to compressional strain in its upper portion, and to tensional strain in its lower portion (198), and must, therefore, embody forms adapted to resisting both, as shown by Fig. 237. A single fish-piece is usually added to the lower side of the joint.

Fig. 237

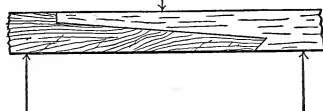

206. A scarf joint for resisting tension and compression may be made, as shown by Fig. 238; or, less complicated, as shown by Fig. 239; or, more secure, as shown by Fig. 240.

Fig. 238



Fig. 239



207. A scarf joint for resisting tension and cross-strain is sometimes made as illustrated by Fig. 241, but this form is

Fig. 240

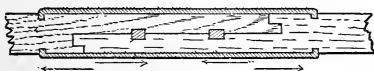
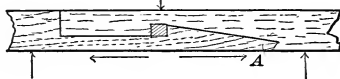

Fig. 241



not so good as the one shown by Fig. 233, if in the latter case the fish-pieces are indented.

JOINTS CONNECTING TIMBERS AT RIGHT ANGLES.

208. **Halving**, Fig. 242, forms a very simple joint, and when well fastened, a strong one. It is frequently employed.

Beveled-halving, Fig. 243, is sometimes resorted to with the view of allowing the load imposed upon *A* in the direction of the arrow, to hold the joint together. Under ordinary circumstances, this joint is likely to prove weak, because of a lack of material at the shoulder near the letter *A*.

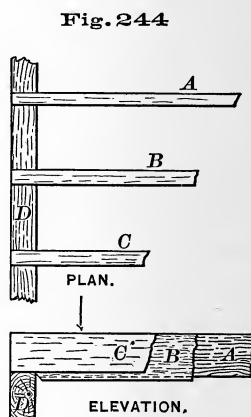
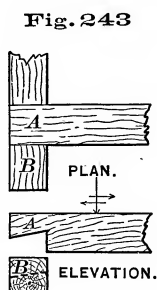
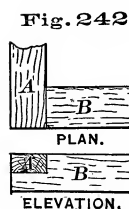

209. **Notching**.— In placing several timbers upon another which is to support them, in the manner represented by Fig. 244, it is usually desired that the tops of the supported timbers be uniform in height. This would not be accomplished by simply placing them in a row, because timbers of the same nominal size vary in their breadth and depth. The ends of the deeper ones must therefore be cut or “notched,” as shown by Fig. 244, to make them agree in depth with the lightest timber of all. Properly speaking, this is a preparation for the bearing of one timber on another, and not a joint; but if the end of the supported timber is allowed to project, as represented by Fig. 245, a true joint is made.

Double-notching requires a notch in both timbers, Fig. 246.

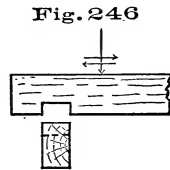
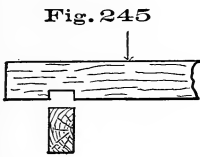

210. **Cogging** is represented by Fig. 247. It has some advantage over notching in point of strength, inasmuch as the timber *B* has its full depth over its support. The "cog" *A* makes the union between the two timbers, as a joint, quite as satisfactory as the double notch.

If the surrounding conditions require it, the cog may be formed near one edge, instead of in the middle of the timber.

211. **Mortise-and-Tenon Joints.**— A tenon is a projection made on the end of a timber to form part of a joint; a mortise is an opening intended to receive a tenon. In Fig. 248, *T* is

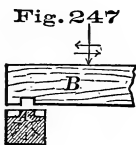

Fig. 248



the tenon; *M*, the mortise; *R*, the root of the tenon; *S, S*, its shoulders; and *c, c*, are sometimes called the abutting cheeks of the mortise.

212. When a vertical timber meets a horizontal timber, the object of the joint is simply to prevent displacement; and a small, short tenon, sometimes called a "stub tenon," is usually employed. In this case, the tenon should not reach the bottom of the mortise, but the strain should be taken by

the shoulders. Sometimes, instead of making a stub tenon, the whole end of one timber is let into another, and the first is then said to be "housed."

213. When a horizontal timber meets a vertical timber, the joint may be formed as shown by Fig. 249, or made much stronger, if, in addition to the tenon, it is "blocked," Fig. 250, or housed as shown by Fig. 251.

Fig. 249

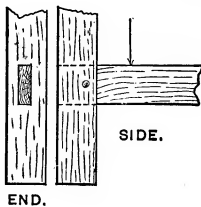
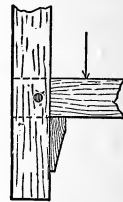

Fig. 250



214. When one horizontal timber meets another, it is a common practice, if the proportions of the pieces are favorable, to employ a double mortise and tenon, Fig. 252, *A* being

Fig. 251

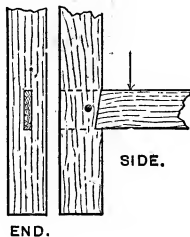
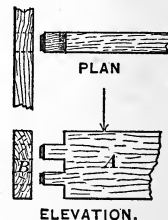
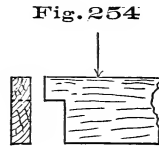
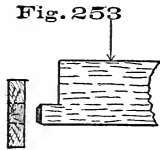

Fig. 252



supported by *B*. This method cannot be recommended, however, because *B* is very much weakened by the mortises. With reference to *B* only, the best place for the mortise is on the neutral axis (in the center of the timber), while with reference to *A* only, the tenon should be on its lower edge, that it may be re-enforced by all the material above it. If timbers

of equal depth are thus joined, they will appear as shown by Fig. 253; but this combination, while strong, is not always practicable, because of surrounding conditions.² For this reason, both mortise and tenon are often placed in unfavorable positions, and the strength of the joint sacrificed. Sometimes the form shown by Fig. 254 is used, but this has little in its



favor, except the ease with which it is made. A better combination is shown by Fig. 255, which, although less perfect as a joint, may serve the purpose quite as well as Fig. 253 if the timber is long between supports. *Tusk tenons* are used to overcome the difficulties presented by the forms shown above when employed in heavy construction. This arrangement of surfaces, Fig. 256, allows the mortise to be in the center of the timber, and to be small; and it also allows the tenon, by means of the tusk *T*, to present a low abutting surface on the supported timber. Its strength and compactness fully compensate for the difficulty of fitting it.

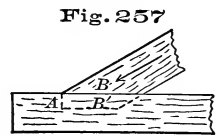
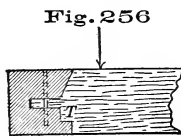
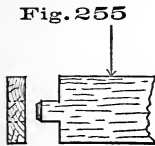

MISCELLANEOUS JOINTS.

215. Oblique Mortises and Tenons may be used to join two timbers meeting each other at an oblique angle. Fig. 257 shows a common form in which the abutting surface, represented by the dotted line *A*, is perpendicular to the cheeks of

the mortise, and the strain transmitted in the direction of the arrow, is divided between the surfaces represented by the dotted line *A* and the full line *B*. A bearing along the latter line becomes unreliable when the timbers shrink, or when, by the settling of connected parts, the surfaces change their relative position. For this reason it is better to depend mainly on the line *A*, which is less affected by the causes mentioned. To take the strain wholly, *A* should be at right angles to the length of the tenon-bearing timber, Fig. 258. This, however, while apparently a well-formed joint, is not a strong one, for the

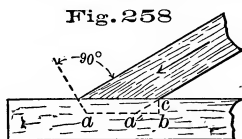

tenon, which is usually equal to but one-third the width of the timber, must alone receive the thrust. To relieve the tenon by increasing the area of the abutting surface, the end of *A* may be housed as shown by Fig. 259, or the joint may be strengthened by bolts or straps.

The mortise for the joint shown by Fig. 258 is usually made of the outline *abc*, and the triangle *a'bc* is not filled. This is done because it is easier to cut down the line *bc* than the line *a'c*. There seems to be no objection to this practice.

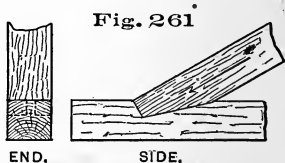
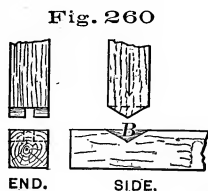

216. A **Bridle-Joint** is represented by Fig. 260. It possesses the advantage of having its parts so exposed that any inaccuracy in the fit is always apparent. An oblique form of

bridle-joint, Fig. 261, is certainly worthy of study. The width of the bridle, *B*, Fig. 260, should not exceed one-fifth the width of the timber.

217. **A Tie-Joint** is shown by Fig. 262. The timber *A* is prevented from falling away in the direction indicated by the arrow, by the insertion of the tie *B*. The joint illustrated by Fig. 197 may be made to serve the same purpose.

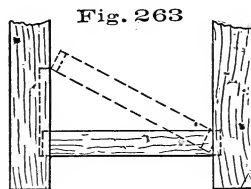
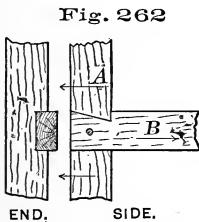

218. **A Chase-Mortise** is a mortise elongated as shown by Fig. 263. Its purpose is to admit a cross-timber between two timbers already fixed. When the cross-timber is in place, that portion of the mortise which is unoccupied may be filled, and the joint thus made secure.



JOINERY.

219. The work of the joiner, unlike that of the carpenter, is usually where it must bear the test of close examination. It is, therefore, necessary that the several pieces of which a whole work is formed, be united by joints that are neat in appearance, or so made as to be hidden from sight. Such joints must be strong even where there is apparently but little strain upon them. Otherwise, the parts are likely to become loose from shrinking and swelling, and to expose unsightly seams.

Some of the joints already described, while particularly adapted to uniting timbers in carpentry, may under given conditions be

equally suitable for the smaller work in joinery. It may also be true that some that are treated in connection with joinery, are quite as useful in carpentry. As already stated, the classification here used only serves to fix in mind a few general principles governing the adaptation of joints; it cannot be arbitrarily adhered to.

The rule in carpentry that makes the simplest form of joint best, does not always hold in joinery, because the methods of the joiner admit of greater accuracy, and also because the pieces of material used are smaller, and consequently less affected by shrinkage.

BEADS AND MOLDINGS.

220. Beads.—A *single-quirked bead* is shown by Fig. 264, *a* being the quirk; a *double-quirked bead* is shown by Fig. 265,

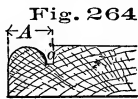

and a *staff*, or *angle*, *bead* by Fig. 266. The term *reading* is applied to a succession of beads, as shown by Fig. 267. A bead is said to be *stuck* when it is formed on the piece of material on which it is used, and *planted* when it is formed on



a separate piece and glued or nailed in place. The size of a bead is indicated by the distance *A*, Fig. 264.

221. Beads are sometimes used wholly for ornament, but they are designed chiefly to conceal cracks by the shadows they cast. It is a principle in joinery, that when two boards

are to be joined they must be made as one complete board, with the joint so concealed that no crack is left, either when first made or after shrinkage ; or there should be a very decided crack, which will appear to have been made intentionally. The first kind of joint is made by means of glue ; but, as the boards forming a surface of considerable width must have some freedom of movement on account of shrinking and swelling tendencies, it follows that when large surfaces are to be covered, glued joints cannot be used. Under such circumstances, it is found best to make no attempt at a close joint, but to allow the

Fig. 268.



PLAN.



ELEVATION.

Fig. 269

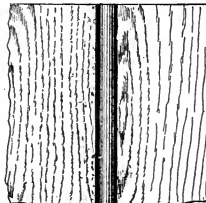

PLAN.



ELEVATION.

Fig. 270

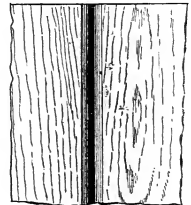

PLAN.



ELEVATION.

pieces to shrink and swell as they may, and depend upon beads to conceal the cracks. Thus the joint shown by Fig. 268 would seem to have been intended for a close fit ; but since it is not, the opening is allowed to remain, and a bead applied, as shown by Fig. 269. The crack is thus converted into a quirk of a bead, and is not noticeable except on close inspection.

222. A *chamfer* is a narrow surface produced, usually, at an angle of forty-five degrees with two other surfaces. Like the bead, it may be used for ornament, or for disguising cracks as shown by Fig. 270.

223. A *stop chamfer* is one which does not extend the full length of the piece on which it is formed. See A, Fig. 212.

224. **Moldings**, while of the same character with beads, are larger and often much more complex in form. They may be stuck or planted. Among the most simple forms is the *ogee*, Fig. 271, which is frequently used as a finish for the edge of a projecting board — a table top, for example.

225. *A round nose*, Fig. 272, is, perhaps, the simplest of all, and is especially useful where a projecting board is subject to usage severe enough to destroy sharp angles or small details, as is the “tread” of a stair.

226. From a few simple forms, of which the two shown are types, have sprung the variety of styles, which, for the most part, have no designation but the number given them by the

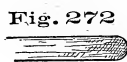

manufacturer. While most of them may be stuck, as is the ogee, Fig. 271, and the common forms shown by Fig. 273, they are generally planted. Fig. 274 shows a molding at *A*, planted on a plain surface; at *B*, one planted in an angle, and



at *C*, a rabbeted (bolection) molding which overlaps one of the pieces forming the angle.

*A fillet*¹ is a light strip of material used in a joint as a fastening, or, in connection with beads and moldings, as a means of ornamentation.

227: In joining boards, use is frequently made of some outside support, which, though not considered a part of the joint, is

¹ Fillet, or *thread*.

often the one element that makes the adaptation of the joint possible. For example, two boards of a floor may be joined to each other in a variety of ways; but they are both supported and retained in position by being fastened to the "flooring joist." A consideration of the joint between the boards, however, need not involve the joist except as a fastening.

HEADING-JOINTS, OR JOINTS FOR UNITING PIECES IN THE DIRECTION OF THEIR LENGTH.

228. The length to which boards may be sawed, is, in practice, limited only by man's ability to handle and transport them with economy. For most purposes, the lengths of from ten to twenty feet which are supplied by the trade, serve as well as longer ones. They can be handled more easily—in other words, more cheaply—than boards of thirty or forty feet.

Fig. 275 shows a *square heading-joint*, which is usually "cut under" a little, as indicated by dotted lines, to insure a close joint on the surface.

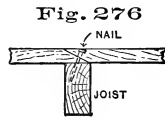
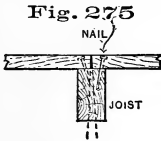

A *splayed heading-joint* is shown by Fig. 276. As a joint, this will seem more perfect than Fig. 275, but it is more difficult to make, and the latter is in most places quite as satisfactory.

JOINTS FOR UNITING PIECES IN THE DIRECTION OF THEIR WIDTH.

229. Joints of this class have two offices to perform: first, to prevent shrinkage from making an open joint; and, secondly, to distribute to adjoining boards, strain that may be received by any one of them at points between supports.

230. Fig. 277 shows at *A* a *plain butt-joint*, which has no provision against opening, and in which the boards do not support each other; it is, really, no joint at all. The same figure shows at *B*, *C*, and *D*, respectively, a *filleted joint*, a *rabbeted joint*, and a *matched joint*. Any of these may be beaded as shown by Fig. 269. The marring of the surface by nail heads may be prevented by "secret nailing," which is shown in Fig. 277.

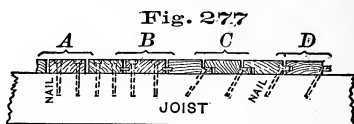

Joints of this class which have no support outside of themselves, must be held by glue.

231. **A Glued Butt-joint**, shown by Fig. 278, if well made, will be quite as strong in the softer woods as a glued matched or a glued filleted joint. It is difficult, however, especially if the boards are long, to keep the two pieces forming the plain joint in proper position while the glue is setting. Even if they are clamped, they are almost sure to slip, so that when the joint has finally become firm, the boards may have assumed a position similar to that shown, Fig. 278. The fillet, and the tongue and

Fig. 278



Fig. 279

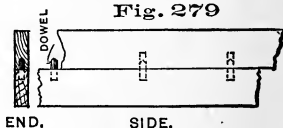

groove (*B* and *D*, Fig. 277) are useful in keeping the parts in place until the glue has hardened. Dowels may be used for the same purpose, Fig. 279. If they are placed at short intervals, and are well fitted, they will add strength to the joint.

232. **Cleating.**—A cleat is a piece of material fastened across the width of a board to prevent its warping; if the sur-

face is composed of several pieces, the cleat is also designed to hold them together. It may be applied to the back of the pieces, as shown by Fig. 280, or across the ends, as shown by Fig. 281. As the grain of the cleat is at right angles to that of the surface to which it is fastened, and since wood shrinks and swells more across the grain than with it, there is likely to be

Fig. 280

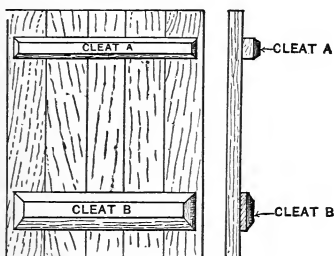
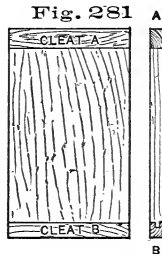

Fig. 281



some movement of one on the other, and the fastenings used to secure the cleat should be of such a nature as to allow it. Otherwise, the edges of the board will be rigidly held, and shrinkage will result in the formation of large cracks, by the splitting of the board somewhere near the center. Screws are undoubtedly the best fastenings, as they will yield, to some degree, without becoming loosened. Nails frequently answer every purpose; and dowels are sometimes used. Glue is unserviceable. When it is used alone, the cleats soon drop off; and when used with other fastenings, it either gives way entirely, or breaks at intervals, causing local cracks.

233. *Side-cleating*, Fig. 280, is the more effective of the two methods, because the cleat may be larger and, for this reason, the fastenings be applied to better advantage. But, when exposed to view, side cleats are unsightly, and are often objectionable because they increase the thickness of the piece as a whole. The proportions of the cleat may vary with the duty expected of it. Other things being equal, *A* will be more effec-

tive than *B*. It is more difficult, however, to put screws or other fastenings through *A* than through *B*; either may be fastened by screws inserted from the face of the board.

234. *End cleats* are neat in appearance, and, when decided warping tendencies are not to be overcome, do good service. To supplement the fastenings, a narrow tongue may be formed on the board to fit a corresponding groove in the cleat, as shown in connection with *B*, Fig. 281.

235. If only one surface of a cleated board is to be made

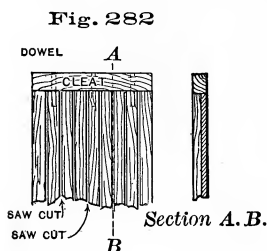

use of,—a drawing board, for example,—the strain on the cleat may be lessened by a succession of saw cuts on the lower side, extending the length of the board, as shown by Fig. 282. By this means, the warping tendency of a seven-eighths-inch board may be reduced to that of a quarter-inch, or even a one-eighth-inch board.

JOINTS FOR UNITING PIECES AT RIGHT ANGLES.

236. **Butt-Joints.**—A plain joint of this kind is represented by Fig. 283. The joint may be concealed by a bead, as indicated by dotted lines; and, when the material is thick and it is desirable to prevent an exposure of end grain as much as possible, the joint may be modified, as shown by Fig. 284. This form also may be beaded. When great strength is demanded,

Fig. 283



Fig. 284



Fig. 285



Fig. 286



a housed joint may be made, Fig. 285. The sides and ends of troughs which are required to be water-tight, are frequently

made in this way. If there can be no projection, as *A*, Fig. 285, this joint may be modified as shown by Fig. 286, but it will lose in strength.

237. Miter-Joint. — Fig. 287 shows a plain miter-joint. Its sole recommendation lies in the fact that it exposes no end grain, for, from a mechanical point of view, it is weak and faulty: weak, because difficult to fasten, and faulty, because, as the two pieces forming the joint shrink, each will become narrower on the lines *A, A*, and produce the change of form shown by the dotted lines *B* and *B'*. As a result of this change, either the angle *C* between the two pieces must become smaller, or the joint must open, forming a wide crack on the inside, which is represented by the triangle *BDB'*.

Miter-joints between two pieces of different thickness are

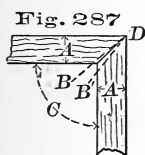

Fig. 288



Fig. 289



made in the form illustrated by Fig. 288. Occasionally this is used when the pieces are of the same thickness, Fig. 289; for while it has the advantages of the plain miter-joint, it is stronger and less affected by shrinkage.

Fig. 290



Fig. 291

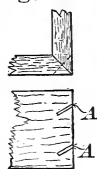

238. Glue, and brads or nails, the usual fastenings for miter-joints, may be supplemented by a fillet inserted as shown by *A*, Fig. 290, or by small pieces inserted in saw cuts which are made across the angle of the joint, as shown by *A*, Fig. 291.

239. **Dovetail-Joints** have already been discussed (171-176). They can be made much stronger than any of the other angle joints herein considered. The plain dovetail, Fig. 199, is sometimes objectionable because it exposes end grain, but the checkered appearance of a well-made joint almost counterbalances this objection. In the lap-dovetail-joint, however, Fig. 201, the end grain disappears from one face, and in the blind dovetail, Fig. 203, from both faces. The blind dovetail certainly combines all that could be desired as far as strength and appearance are concerned ; but it is difficult to make.

240. **Mortise-and-Tenon Joints** in joinery are different from those employed in carpentry, only in the proportions of their parts, and the accuracy with which they are fitted. When the thickness B , Fig. 292, of the pieces joined is the same, the

Fig. 292

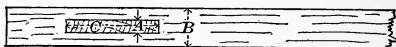

thickness A , of a simple tenon may vary from one-third to one-half that of the piece on which it is formed, practice tending toward the larger figure ; and its breadth C ought not to exceed seven times its thickness. For the thickness given, Fig. 292 shows a tenon of the greatest breadth allowable. The breadth is thus limited because the sides of the mortise derive their support from the solid material at its ends, and they become too weak for good service when the limit named is

Fig. 293

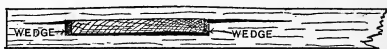

exceeded. Again, the tenon, if too broad, will not stand the pressure of wedging, but is likely to become distorted, thus putting additional strain on the mortise, and frequently causing it to split. See Fig. 293.

241. When the piece on which the tenon is to be formed is very broad, a single tenon, if employed, leaves wide shoulders, *AB*, Fig. 294. These are open to objection, because of the tendency of the tenon piece to warp so that its surface at *D* will not agree with the surface of the piece it joins, at *C*. Under such circumstances a *double tenon*, Fig. 295, may be used. This will give the support that is needed, and will not violate the principle laid down in 240. Double tenons, however, while they obviate one difficulty introduce another. The tenons are unyielding, and, if the piece is very wide, its shrinkage is likely to produce a crack between them, as denoted by the dotted lines *A*, Fig. 295.

Fig. 294

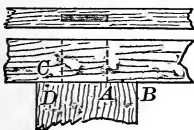
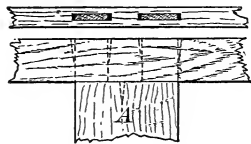

Fig. 295



242. *Haunching* is a device by which the tenon proper is supplemented by very short tenons, or "haunches," as indicated by the dotted outline, Fig. 296. The entire end of the tenon piece is thus inserted in the mortise piece, and prevented from warping; the danger of its splitting from shrinkage is not increased. If the piece shown by Fig. 294 were haunched, the imperfection it illustrates would be removed.

Fig. 296

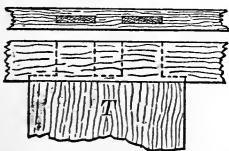
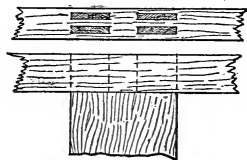

Fig. 297



243. *Four tenons* may be used in a single joint when the pieces to be united are very thick and wide, Fig. 297. By their use the parts are made small enough to prevent shrinkage from producing a bad joint.

244. In forming a joint at the extremity of the mortise piece, a single tenon, if employed, must be cut away at one side, as shown by Fig. 298: Such a joint may be haunched, Fig. 299, or if the pieces are sufficiently wide, two tenons may be used, Fig. 213.

Fig. 298

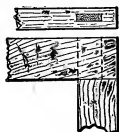
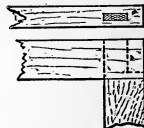

Fig. 299



245. Mortise-and-tenon joints in joinery are capable of all the modifications of form which they are made to assume in carpentry. They may be housed, for example, or made in any of the oblique forms.

PANELING.

246. A **Panel** is a board, or a combination of boards, employed to fill an opening within a frame. Thus, in Fig. 300 the pieces *F* constitute the frame, and the pieces *A*, *B*, *C*, and *D* are panels. The primary purpose of this arrangement is to give an extended surface of wood so constructed that the pieces of which it is made shall be well and neatly fastened, and, at the same time, the dimensions and the general appearance of the whole, be unaffected by shrinking or swelling. To enhance the attractiveness of the surface, both frame and panel are frequently embellished, sometimes so richly that we lose sight of the mechanical necessity of the panel, and come to regard it as a means of decoration.

247. **The Frame** taken by itself is, in general, made up of vertical and horizontal pieces united by mortise-and-tenon joints. Vertical pieces extending the full length of any frame

Fig. 300

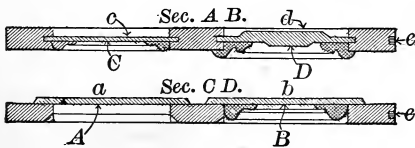
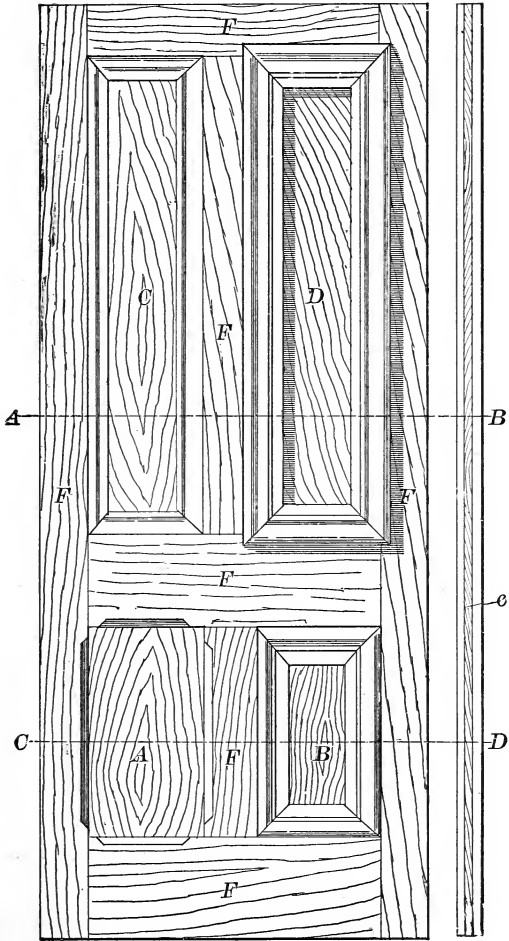

are called "stiles," and horizontal pieces, "rails." Each of these parts should be as narrow as is consistent with the degree of strength required. The width of a rail should never be more than twice that of the stile, which, as a rule, should not exceed four and a half inches. A consideration of Fig. 300 will show that, although the door is three or more feet wide, the only surfaces whose shrinkage can affect the width are the two $4\frac{1}{2}$ -inch stiles. Large surfaces are covered, not by increasing the size of the parts, but by increasing their number.

The fillet e is inserted to cover the end of the tenons, which would otherwise show on the edge of the door.

248. The panel may be either fastened to the back of the frame, or inserted in a groove, or "plow," made in the frame to receive it. In either case, provision must be made for shrinking and swelling. When fastened to the back, screws are usually found to make a sufficiently yielding joint. When fitted into the frame, no fastening is needed beyond that derived from its position. It must fit loosely enough to draw out on shrinking, but not so loosely as to rattle.

In Fig. 300, A is a plain panel screwed to the back of the frame, and the frame about it is stop-chamfered. This is, probably, the simplest combination of frame and panel. In common with all panels fastened in this way, it is best adapted to work that is to be seen from one side only, as a closet door, or the permanent lining of a room.

B shows a plain panel fastened to the back of a frame which is ornamented by a molding.

C differs from B only in being let into the frame instead of being screwed to the back. The reverse face c may be ornamented by a molding in the same manner as C , or by a chamfer.

D shows a raised panel embellished by a rabbeted molding. The reverse face d is a plain raised panel.

A panel and frame may be plain on one side and ornamented on the other, the ornamentation on one side may differ from that on the other, or the sides may be similar; and any form of embellishment that may properly be applied to board surfaces, may be used in connection with this work.



FASTENINGS.

249. Pins are employed principally as a means of holding tenons in mortises. In carpentry one pin, generally, is used in each joint, its diameter varying from one-sixth to one-fourth the width of the tenon. It is commonly placed at a distance from the abutting cheeks of the mortise, equal to one-third the length of the tenon. But to secure the maximum strength of the joint, its exact location in any particular case must be fixed with reference to the character of the material, and also to the relative thickness of the tenon and the cheeks of the mortise. In joinery, it is found best to use two or more pins, and, whatever the proportions of the joint may be, these rarely exceed three-eighths of an inch in diameter. They are inserted very near the abutting cheeks of the mortise, so that that part of the mortise between them and the shoulder of the tenon, will not shrink enough to make an open joint.

Square pins are better than round ones, but the latter are more easily fitted and, therefore, more used.

Drawboring has already been described (168).

250. Wedges.—The most common use of wedges is illustrated by Fig. 213 in connection with Exercise No. 14, which requires wedges to be dipped in glue, and driven between the tenon and the ends of the mortise. Wedges are also driven in saw cuts made in the end of the tenon for the purpose of

expanding it, as illustrated by Fig. 301, which shows at *A* a section of a joint before the wedges are driven, and at *B* a section of the finished joint. The saw cut should extend somewhat deeper than the point reached by the wedge. If the tenon is broad, or if a considerable increase in breadth is

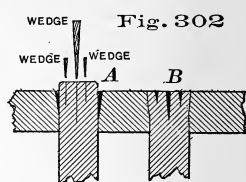
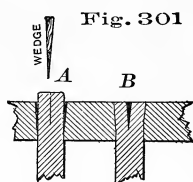

required, more than one wedge must be used. When there are more than two, a large one should be inserted in the center, and smaller ones on each side, as shown by Fig. 302, the wedges ready for driving at *A*, and the joint finished at *B*.

251. *Blind-wedging* is sometimes resorted to when the mortise does not extend through the piece. As shown by Fig. 303, the mortise is enlarged at the bottom and the wedges started in; then, as the pieces are driven together, the ends of the wedges strike against the bottom of the mortise and spread the tenon. When driven, the tenon cannot be withdrawn.

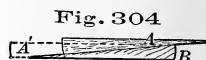
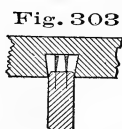

252. **Keys** differ from wedges in respect of their sides, which are parallel or nearly so. The key may be a single piece, as shown in the joint, Fig. 197, or, what is better, made as two wedges, Fig. 304. These may be put in place when in the relative position shown by *A'B*, after which, by driving them upon each other, as indicated by *A*, *B*, the joint may be tightened. The parallelism of the outside edges, which are in contact with the joint, is always maintained.

253. Dowels are round wooden pins of small diameter used to strengthen a joint. They should be dipped in glue and driven at a tight fit into holes made for their reception. They may be carried entirely through one piece and into the other, Fig. 282, or inserted as shown by Fig. 279.

Dowels may be made at the bench by the plane, or they may be turned. When planed, they will be improved in section if driven through a round hole in a piece of iron or steel. They are supplied by the trade, of all ordinary diameters, and in lengths of several feet, so that the consumer has but to cut them to lengths suited to his purposes, and point them.

Shoe pegs serve well as small dowels. After being dipped in glue, they should be driven in brad-awl holes.

Whenever fastenings are required to be so placed that subsequent operations bring the cutting tools about them, dowels are preferable to brads or nails, since they may be planed off without injury to the tool.

254. Nails are classified according to the process by which they are made; the material used; their form and proportions; and the use for which they are intended. Iron and steel are

the most common materials, but when these would be destroyed by corrosion, copper and "galvanized" iron are used. The forms of most importance to the bench-worker, may be classed as *common* and *finishing* (or *casing*) nails. Their comparative proportions are illustrated by Figs. 170 and 305, the former representing a common, and the latter a finishing nail. It is evident that the greater strength of the common nail

Fig. 305



Fig. 170

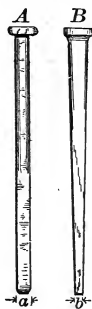

makes its use desirable when there is sufficient material to receive it properly, and when the appearance of the head on

the surface is not objectionable. The finishing nail may be used in more delicate material, and makes a smaller scar on the work.

Cut nails are so called because, in the process of manufacture, each nail is cut from a plate of metal. The plate has a width equal to the length of the nail, and a thickness equal to its breadth. Generally speaking, all nails of the form shown by Figs. 170 and 305 are cut.

Wrought, as distinguished from cut nails, are those which without breaking will bend sufficiently for clinching. As the term suggests, such nails were formerly wrought under the hammer, it being impossible to obtain the requisite quality by machinery; and they were so made long after common nails had ceased to be made by hand. In later years, however, wrought nails have in reality been cut, but from better material and by more perfect processes than those which have been technically called cut nails.

Steel cut nails are now generally introduced in this country, and will in time take the place not only of the iron cut, but also of the so-called wrought nails; for, while less expensive than the former, they are equal in quality to the latter.

Fig. 306



Wire nails, Fig. 306, are at this time coming into general use. Their strength and tenacity are unequalled. They are made from drawn wire in sizes varying from that of the smallest brad to that of the largest spike.

255. The length of nails is indicated by numbers prefixed to the word "penny," as 6-penny, 8-penny, terms¹ which are

¹ It has been suggested that they once indicated the value or price of a given number of nails, 6-penny nails being sold at six pence per hundred, and 8-penny nails for eight pence per hundred. Another explanation is that *penny*, as here used, is a corruption of *pound*, 6-penny meaning that

now used arbitrarily, though, originally, they were doubtless significant.

The length of nails of ordinary sizes is given as follows:—

A 3-penny nail	is one inch long.
A 4-penny	“ one and one-fourth inches long.
A 5-penny	“ one and three-fourths “ “
A 6-penny	“ two “ “
A 7-penny	“ two and one-fourth “ “
An 8-penny	“ two and one-half “ “
A 10-penny	“ two and three-fourths “ “
A 12-penny	“ three “ “
A 20-penny	“ three and one-half “ “

256. Brads are small finishing nails, in form similar to the nail shown by Fig. 305, the smaller ones being thicker, and the larger ones more slender. Their size is expressed in inches and fractions of an inch, and ranges from one-fourth of an inch to two inches.

257. Tacks are useless for fastening pieces of wood to each other, but are indispensable when lighter material, like cloth or leather, is to be fastened to wood. They vary in form and size with the particular use for which they are intended. Their size is expressed by a number prefixed to the word “ounce.”¹ The length of the more common sizes varies as follows:—

A 1-ounce tack	is three-sixteenths of an inch long.
A 2-ounce	“ one-fourth “ “ “
A 3-ounce	“ three-eighths “ “ “
A 4-ounce	“ seven-sixteenths “ “ “
A 6-ounce	“ one-half “ “ “
An 8-ounce	“ nine-sixteenths “ “ “
A 10-ounce	“ five-eighths “ “ “

a thousand nails weighed six pounds; 8-penny, that a thousand weighed eight pounds, and so on.

¹This expression may have once represented the weight of 1000 tacks; for example, 1000 tacks $\frac{3}{16}$ ” long, weighed one ounce, and were, therefore, called “one-ounce” tacks.

258. **Common Screws** are either *bright* or *blued*, *steel* or *brass*, *round-headed* or *flat-headed*.

Bright screws are finished by polishing. When blued, the luster of the polish has been taken off by heat or an acid, and a deep blue finish produced. Blued screws will not rust so easily as bright screws, and in most work they look better—considerations which apply with still greater force to the use of brass as a material instead of steel.

Flat-headed screws, shown by Fig. 124, are the most common. When used on finished surfaces, the heads should be sunk below the general level and the hole above them filled. When this is not convenient, round heads, which in the finished work will appear above the surface, are frequently employed.

The size of screws is indicated by their length in inches or fractions of an inch, and by the diameter of the wire forming the body; this diameter is expressed by a number which refers to a "standard screw gauge." The sizes of the screw gauge range from No. 0, which represents a diameter of a little less than a sixteenth of an inch, to No. 30, which represents a diameter somewhat greater than seven-sixteenths of an inch. The size of a screw two inches long and a quarter of an inch in diameter would be written 2" × No. 15.

259. **Glue** is chiefly of two kinds, which are known as animal, and fish glue. Animal glue is a product obtained from the refuse of tanneries (bone, horn, hoofs, and bits of hide), which gives up the glutinous matter it contains when boiled under pressure. Fish glue is extracted from the spawn and entrails of fish. As prepared for the market, both are generally in the form of cakes, varying in thickness from an eighth of an inch to very thin chips, according to the quality and character of the glue. For bench work, these are dissolved in water, and the mixture applied hot. For convenience in dissolving the glue, a glue-pot is used, which is an arrangement of two vessels, one

within another, the inner being for glue, the outer for water. Heat is communicated in any convenient way to the water, and the water in turn heats the glue. The use of the vessel of water is to prevent the glue from burning.

Gluing. — When ready for use, the glue should be hot and of the consistency of thin sirup. It must be applied with a brush, in a thin, uniform coating to both surfaces that are to be joined. Too much glue will prevent the pieces from coming together in the joint. The application should be made as quickly as possible because the glue begins to cool and set as soon as it is taken from the pot; it will set less quickly if the pieces to be glued are warmed. After the pieces have been put together, they should be rubbed to squeeze out the surplus glue, and finally clamped in place and allowed to remain until dry — at least twelve hours.

Liquid glues are supplied by the trade. They require no heating and are, therefore, always ready for use.

When end grain is to be glued, it must first be sized, that is, coated with thin glue, in order to fill the pores of the wood, and allowed to dry before the joint is made. Otherwise, the glue that is put into the joint is drawn off into the grain and becomes useless as a fastening.



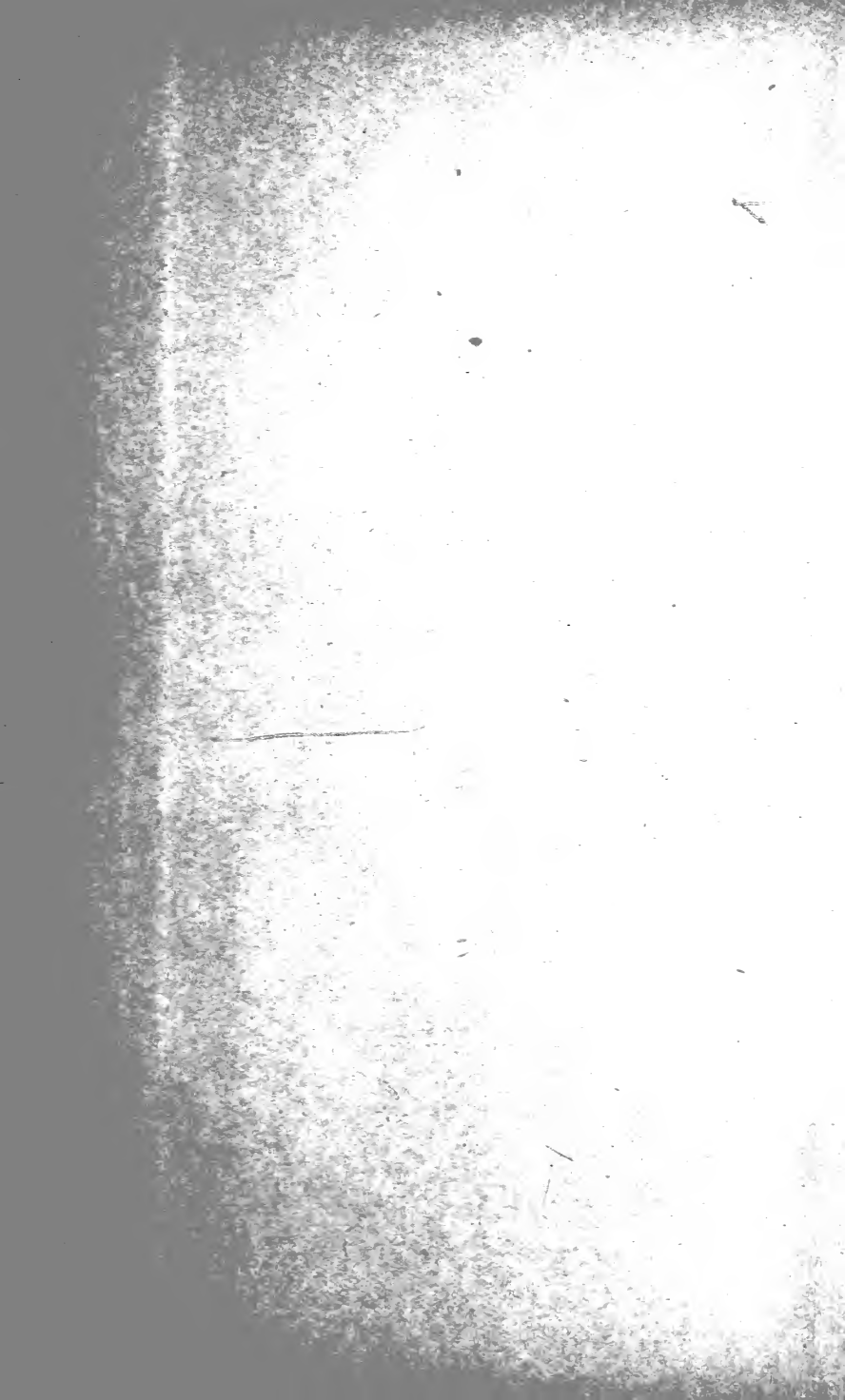

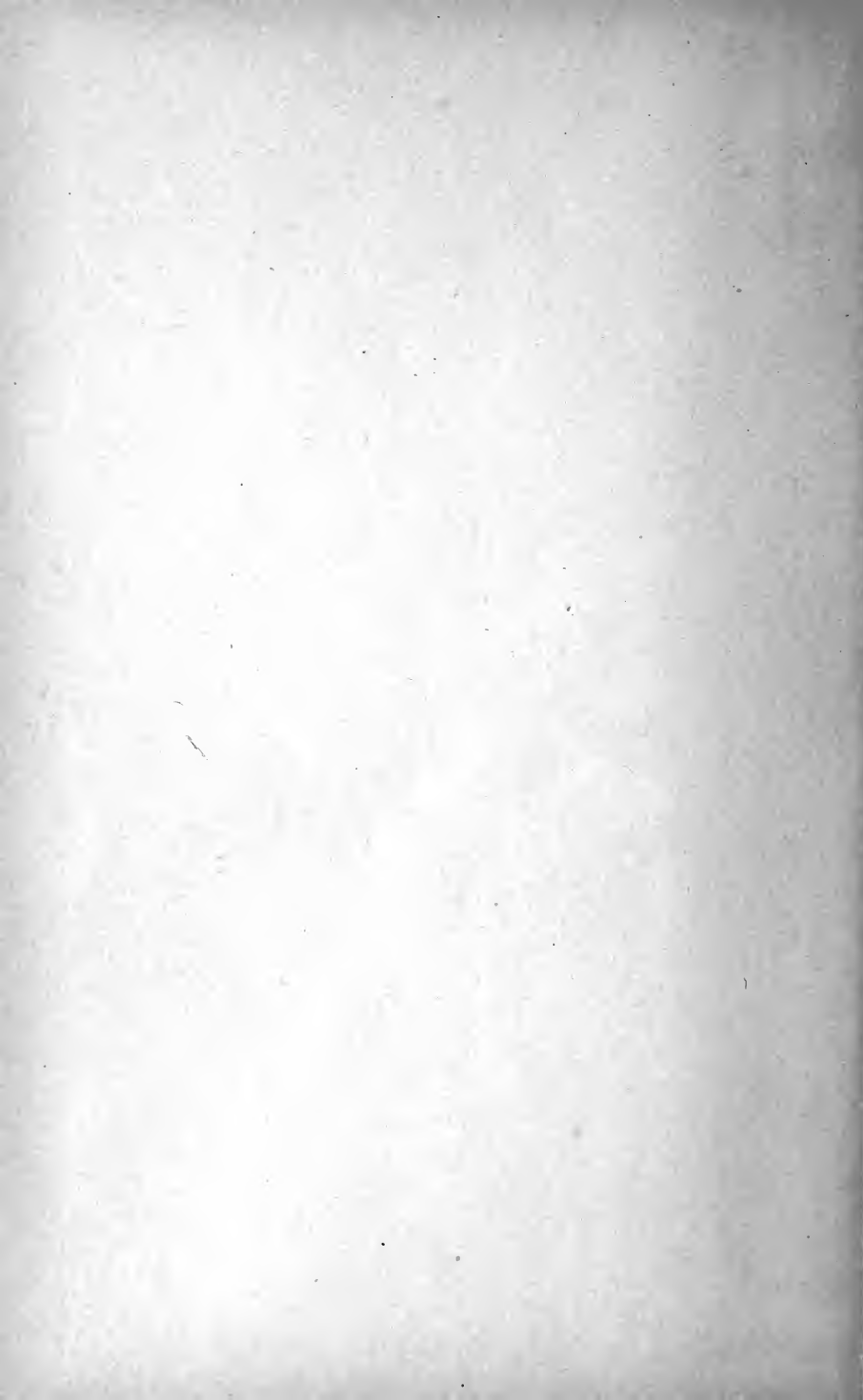



MAR 28 1904

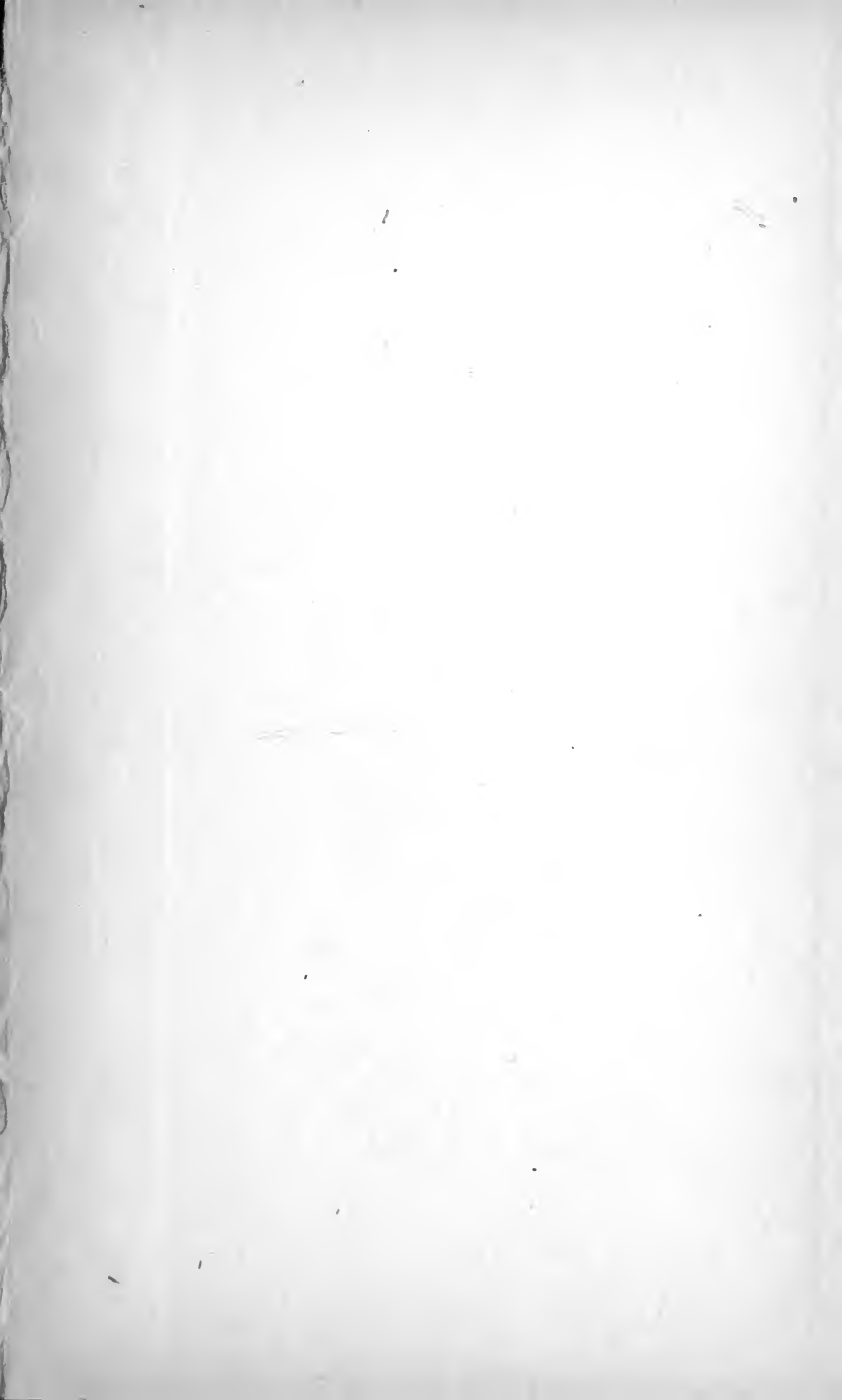

LIBRARY OF CONGRESS



0 013 824 492 1 ●